



DLP TV

Chassis : L64C(N_ATSC)_Hurricane-2
Basic Model : HLR4266WX/XAA (HL-R4266W)
Model : SP42L6HNX/XAX (SP-42L6HN)

SERVICE Manual

DLP TV



SP-42L6HN

FEATURES

- HD Built in TV
- NTSC/ATSC Tuner Embedded
- AV network system (Anynet)
- Digital Audio output (OPTICAL) jack
- Firmware upgrade by USB Port

Table of Contents

Chapter 1 Precaution

■ 1-1 Safety Precautions	1-1
■ 1-2 Servicing Precautions	1-3
■ 1-3 Static Electricity Precautions	1-4
■ 1-4 Installation Precautions	1-5

Chapter 2 Product Specification

■ 2-1 Product Features	2-1
■ 2-2 Key Features	2-2
■ 2-3 Specifications Analysis	2-4
■ 2-4 Accessories	2-5

Chapter 3 Alignment & Adjustment

■ 3-1 Service Instruction	3-1
■ 3-2 How to Access Service Mode	3-2
■ 3-3 Factory Data	3-3
■ 3-4 Service Adjustment	3-13
■ 3-5 Software Upgrade	3-16
■ 3-6 Replacements & Calibration	3-17

Chapter 4 Exploded View & Part List

■ 4-1 SP42L6HNX/XAX	4-1
---------------------------	-----

Chapter 5 Electrical Part List

■ 5-1 SP42L6HNX/XAX Service Item	5-1
--	-----

Chapter 6 Troubleshooting

■ 6-1 Checkpoints by Error Mode	6-1
■ 6-2 Troubleshooting Procedures by Error Modes	6-7
■ 6-3 Troubleshooting Procedures by ASS'Y	6-9

Chapter 7 Block Diagram

■ 7-1 Overall Block Diagram	7-1
■ 7-2 Partial Block Diagram	7-2

Chapter 8 Wiring Diagram

■ 8-1 Overall Wiring	8-1
■ 8-2 Connection between Analog and Digital Board	8-2

Chapter 9 PCB Diagram

■ 9-1 Power Board	9-1
■ 9-2 Digital Board	9-3
■ 9-3 Analog Board	9-6
■ 9-4 DMD Board	9-9

Chapter 10 Schematic Diagram

■ 10-1 Analog Board	10-1
■ 10-2 Digital Board	10-10
■ 10-3 DMD Board	10-28
■ 10-4 Actuator Board	10-35
■ 10-5 Ballast	10-36
■ 10-6 Power Board	10-37
■ 10-7 Combined Bridge and Control Module	10-38
■ 10-8 Detect	10-39
■ 10-9 Side-AV	10-40
■ 10-10 Key Control	10-40
■ 10-11 RMC-LED	10-40

1. Precaution

To avoid possible damages or electric shocks or exposure to radiation, follow the instructions below with regard to safety, installation, service and ESD.

1-1 Safety Precautions

1. Make sure all protective devices are properly installed including non-metallic handles and compartment covers when installing or re-installing the chassis or chassis assemblies.
2. Make sure that no gaps exist between the cabinets for children to insert their fingers in to prevent children from receiving electric shocks.

Errors may occur when the resistance is below 1.0 M Ω or over 5.2 M Ω .

In these cases, make sure that the device is repaired before sending it back to the customer.

3. Check for Electricity Leakage (Figure 1-1)
Warning: Do not use an insulated transformer for checking the leakage. Use only those current leakage testers or mirroring systems that comply with ANSIC 101.1 and the Underwriter Laboratory's specifications (UL1410, 59.7).

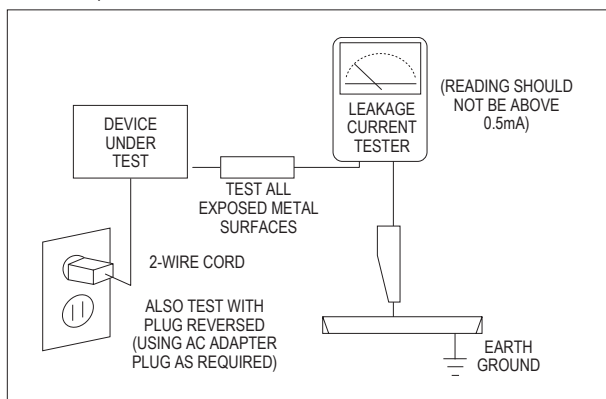

Fig. 1-1 AC Leakage Test



4. A high voltage is maintained within the specified limits using safety parts, calibration and tolerances. When voltage exceeds the specified limits, check each special part.
5. Warning for Engineering Changes:
Never make any changes or additions to the circuit design or the internal part for this product.
Ex: Do not add any audio or video accessory connectors. This might cause physical damage.
Furthermore, any changes or additions to the original design/engineering will invalidate the warranty.
6. Warning - Hot Chassis:
Some TV chassis are directly connected to one end of the AC power cord for electrical reasons.
Without insulated transformers, the product can only be repaired safely when the chassis is connected to the earthed end of the AC power source.

To make sure the AC power cord is properly connected, follow the instructions below. Use the voltmeter to measure the voltage between the chassis and the earthed ground. If the measurement is over 1.0V, unplug the AC power cord and change the polarity before re-inserting it. Measure the voltage between the chassis and the ground again.
7. Some TV chassis are shipped with an additional secondary grounding system. The secondary system is adjacent to the AC power line. These two grounding systems are separated in the circuit using an unbreakable/unchangeable insulation material.
8. When any parts, material or wiring appear overheated or damaged, replace them with new regular ones immediately. When any damage or overheating is detected, correct this immediately and make a regular check of possible errors.
9. Check for the original shape of the lead, especially that of the antenna wiring, any sharp edges, the AC power and the high voltage power. Carefully check if the wiring is too tight, incorrectly placed or loose. Never change the space between the part and the printed circuit board. Check the AC power cord for possible damages. Keep the part or the lead away from any heat-emitting materials.

Precaution

10. Safety Indication:

Some electrical circuits or device related materials require special attention to their safety features, which cannot be viewed by the naked eye. If an original part is replaced with another irregular one, the safety or protective features will be lost even if the new one has a higher voltage or more watts.

Critical safety parts should be bracketed with ( ). Use only regular parts for replacements (in particular, flame resistance and dielectric strength specifications). Irregular parts or materials may cause electric shock or fire.

11. Pay additional attention to the current leakage as the voltage between the power board and the ballast is 220 to 440v, i.e. very high.
And also beware of possible electric shock from the primary power source.

1-2 Servicing Precautions

Warning 1: First carefully read the "Safety Instruction" in this service manual.

When there is a conflict between the service and the safety instructions, follow the safety instruction at all times.

Warning 2: Any electrolytic capacitor with the wrong polarity will explode.

1. The service instructions are printed on the cabinet, and should be followed by any service personnel.
2. Make sure to unplug the AC power cord from the power source before starting any repairs.
 - (a) Remove or re-install parts or assemblies.
 - (b) Disconnect the electric plug or connector, if any.
 - (c) Connect the test part in parallel with the electrolytic capacitor.
3. Some parts are placed at a higher position than the printed board. Insulated tubes or tapes are used for this purpose. The internal wiring is clamped using buckles to avoid contact with heat emitting parts. These parts are installed back to their original position.
4. After the repair, make sure to check if the screws, parts or cables are properly installed. Make sure no damage is caused to the repaired part and its surroundings.
5. Check for insulation between the blade of the AC plug and that of any conductive materials (i.e. the metal panel, input terminal, earphone jack, etc).
6. Insulation Check Process: Unplug the power cord from the AC source and turn the switch on. Connect the insulating resistance meter (500v) to the AC plug blade.

The insulating resistance between the blade of the AC plug and that of the conductive material should be more than 1 M Ω .
7. Any B+ interlock should not be damaged.
If the metal heat sink is not properly installed, no connection to the AC power should be made.
8. Make sure the grounding lead of the tester is connected to the chassis ground before connecting to the positive lead. The ground lead of the tester should be removed last.
9. Beware of risks of any current leakage coming into contact with the high-capacity capacitor.
10. The sharp edges of the metal material may cause physical damage, so ensure wearing protective gloves during the repair.

1-3 Static Electricity Precautions

1. Some semi-conductive ("solid state") devices are vulnerable to static electricity. These devices are known as ESD. ESD includes the integrated circuit and the field effect transistor. To avoid any materials damage from electrostatic shock, follow the instructions described below.
2. Remove any static electricity from your body by connecting the earth ground before handling any semi-conductive parts or ass'ys. Alternatively, wear a dischargeable wrist-belt.
(Make sure to remove any static electricity before connecting the power source - this is a safety instruction for avoiding electric shock)
3. Remove the ESD ass'y and place it on a conductive surface such as aluminum foil to prevent accumulating static electricity.
4. Do not use any Freon-based chemicals. Such chemicals will generate static electricity that causes damage to the ESD.
5. Use only grounded-tip irons for soldering purposes.
6. Use only anti-static solder removal devices. Most solder removal devices do not support an anti-static feature. A solder removal device without an anti-static feature can store enough static electricity to cause damage to the ESD.
7. Do not remove the ESD from the protective box until the replacement is ready. Most ESD replacements are covered with lead, which will cause a short to the entire unit due to the conductive foam, aluminum foil or other conductive materials.
8. Remove the protective material from the ESD replacement lead immediately after connecting it to the chassis or circuit ass'y.
9. Take extreme caution in handling any uncovered ESD replacements. Actions such as brushing clothes or lifting your leg from the carpet floor can generate enough static electricity to damage the ESD.

CAUTION

These servicing instructions are for use by qualified service personnel only. To reduce the risk of electric shock do not perform any servicing other than that contained in the operating instructions unless you are qualified to do so.

1-4 Installation Precautions

1. For safety reasons, more than two people are required for carrying the product.

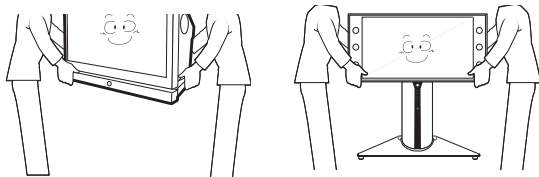

2. Keep the power cord away from any heat emitting devices, as a melted covering may cause fire or electric shock.
3. When installing the product, make sure to keep it away from the wall (more than 10cm/4 inches) for ventilation purposes. Poor ventilation may cause an increase in the internal temperature of the product, resulting in a shortened component life and degraded performance.
4. Bend the external antenna cable when connecting it to the product. This is a measure to protect it from being exposed to moisture. Otherwise, it may cause a fire or electric shock.

5. Make sure to turn the power off and unplug the power cord from the outlet before repositioning the product. Also check the antenna cable or the external connectors if they are fully unplugged. Damage to the cord may cause fire or electric shock.
6. Keep the antenna far away from any high-voltage cables and install it firmly. Contact with the high-voltage cable or the antenna falling over may cause fire or electric shock.
7. When connecting the RF antenna, check for a DTV receiving system and install a separate DTV reception antenna for areas with no DTV signal.
8. Check the basics of the screen test.
- Image position/size, Tilt adjustment, Actuator activation

MEMO

2. Product Specification

2-1 Product Features

Block	Specification	Major IC	Remark
DMD	- Panel Resolution : 1280 x 720 (Diamond Pixel)	HD4 DMD Panel(L620 Engine)	
RF	- Integrated HDTV Tuner (NTSC/ATSC TUNER Embedded)	ATI T313	
Power	- Input Voltage : AC110V - Stand-By : under 30W	Stand-by (KA1M0565)	
Video	- DNIe3- NTSC, ATSC- HDM	ADV7401, ATI X226B	
Sound	- Speaker : 15W x 2 - Dolby Digital	MSP4440	
Cabinet	- L3 Design		

■ Chip Description

- ATI x226B : Xilleon 226 is the most advanced and highly integrated component for digital set-top boxes, information appliances, and televisions. Xilleon 226 provides dual-stream high-definition decode and display, an assortment of peripheral device controllers, and an embedded microprocessor.
- ADV7401 : The ADV7401 is an integrated video decoder that automatically indicates and converts High Definition or Standard Definition analog baseband television signal into a 4:2:2 component digital video data stream compatible with 20/16-bit or 10/8-Bit CCIR601/CCIR656 outputs for standard definition & SMPTE293M/296M/274M & ITU-R.BT1358 for High definition. All RGB graphics signals are output as 30-bit 4:4:4 RGB or 20-bit 4:2:2 YCrCb.
- MSP4440 : The MSP 44x0G family of single-chip Multistandard Sound Processors covers the sound processing of all analog TV-Standards worldwide, as well as the NICAM digital sound standards.

2-2 Key Features

Model	SP-42L6HN	SP-46L6HN	SP-50L6HN
Voltage	AC 110-120V~	AC 110-120V~	AC 110-120V~
Frequency of Operation	60Hz	60Hz	60Hz
Power Consumption	230 watts	230 watts	230 watts
Dimensions (W x D x H)	39.33 x 13.03 x 30.53 inches 999 x 331 x 755.5 mm	43.07 x 13.35 x 32.05 inches 1094 x 339 x 814 mm	46.54 x 14.13 x 34.25 inches 1182 x 359 x 870 mm
Weight	28 Kg / 61.72 lbs	32.5 Kg / 71.65 lbs	36 Kg / 79.37 lbs

■ H/W Configuration

- DMD Panel : 0.55" (1280 x 720p, TI)
- 1 Optical Engine for the Panel : Slim and Cost-effective
- Color Wheel : R/G/B Color Implementation
- Lamp : 100W (10,000 hours) → Dynamic Mode 120W Drive (6,000 hours)
- Support HDMI Interface : Adopts DVI/HDMI systems for digital HDs including STB.
- DNle3 : High quality image implementation
- AnyNet Feature : An enhanced interface for various external devices
- USB Interface : Use the USB interface for service purposes (S/W Upgrade)

■ S/W Configuration

- MCU : Built-in 300 MHz MIPS X226B CPU
- 4-Layered Architecture : Device Driver/OS/Hardware Abstraction/Application
- OSD : 32Bit True Color Graphics OSD
- Enhanced system stability by separating the DTV control and the application control systems into multi-processes.

■ Picture

- DMD Panel
 - * Panel Size : 0.55"
 - * Panel Resolution : 1280 x 720 (Diamond Pixel)
- Tuner : Integrated HDTV Tuner (NTSC/ATSC TUNER Embedded)
- Display Format : 1280 x 720 (Diamond Pixel)

■ Sound

- Sound System : Dolby Digital
- Amp/Channel : 2 Channel Digital Amp
- Speaker System & Output(RMS)
 - * Main L/R : 15W + 15W
 - * Sound (RMS) : 15W + 15W

■ In/Out Terminals

- Side : 1 CVBS In, 1 S-VHS In
- Rear : 2 RF In, 2 CVBS In, 2 S-VHS In, 2 Component In,
1 HDMI In(DVI Comportable With Adaptive Jack Only), 1 Anynet port, 1 Optical audio

■ Feature

- Component Interface (480i/480p/720p/1080i, Y/Pb/Pr)
- Digital Interface : HDMI
- Language : English/French/Spanish
- Picture Size : 4:3/16:9/Zoom1/Zoom2/Panorama
- V-CHIP
- Closed Caption
- Sleep Timer : 180 Min.
- Anynet Interface
- Optical sound output







■ Remocon

- TM76





■ Power Supply

- 110V

2-3 Specifications Analysis

Model		SP-42L6HN	SP-46L6HN	SP-50L6HN	HL-R5087W	HL-R6156W	HL-R4266W
Design							
Picture	Display Device	DLP	DLP	DLP	DLP	DLP	DLP
	Built-in Tuner	ATSC, NTSC	ATSC, NTSC	ATSC, NTSC	ATSC, NTSC	ATSC, NTSC	ATSC, NTSC
	Display Format	1080i, 720p, 480p, 480i	1080i, 720p, 480p, 480i	1080i, 720p, 480p, 480i	1080i, 720p, 480p, 480i	1080i, 720p, 480p, 480i	1080i, 720p, 480p, 480i
	Screen Size	42 inch	46 inch	50 inch	50 inch	56 inch	42 inch
	Aspect ratio	16:9	16:9	16:9	16:9	16:9	16:09
	Progressive scan	Yes	Yes	Yes	Yes	Yes	Yes
	Digital Comb Filter	4H Comb	4H Comb	4H Comb	3D Comb	4H Comb	4H Comb
	First Surface Mirror	Yes	Yes	Yes	Yes	Yes	Yes
	Brightness	750cd/m ²	750cd/m ²	750cd/m ²	800cd/m ²	750cd/m ²	750cd/Œ ³
	Contrast	1500:1	1500:1	1500:1	2500:1	1500:1	1500:1
	Color Wheel Size/Bearing	7segment/65 Œ , Air Bearing	7segment/65 Œ , Air Bearing	7segment/65 Œ , Air Bearing	7segment/65 Œ , Air Bearing	7segment/65 Œ , Air Bearing	7segment/65Œ6 Air Bearing
	Anti-glare Sun Screen	Yes	Yes	Yes	Yes	Yes	Yes
	Screen Pitch	0.098mm	0.098mm	0.098mm	0.098mm	0.098mm	0.098mm
	Image enhancer	DNle3	DNle3	DNle3	DNle3	DNle3	DNle3
Audio	Base/Tremble/Balance	No	No	No	No	No	No
	Equalizer	5 Band	5 Band	5 Band	5 Band	5 Band	5 Band
	Auto Volume Leveler	Yes	Yes	Yes	Yes	Yes	Yes
	Surround Sound	DNSE Dolby Digital	DNSE Dolby Digital	DNSE Dolby Digital	TruSurround XT Dolby Digital	DNSE Dolby Digital	DNSE Dolby Digital
	Speaker system	2 Way 4 Speaker	2 Way 4 Speaker	2 Way 4 Speaker	2 Way 4 Speaker	2 Way 4 Speaker	2 Way 4 Speaker
	Output Power	15Wx2	15Wx2	15Wx2	15Wx2	15Wx2	15Wx2
Features	2-Tuner Split-Screen PIP	No	No	No	Yes(HD/SD)	No	Yes(HD/SD)
	Split-screen Side-by-Side	No	No	No	Yes	No	Yes
	MTS with dbx Noise Reduction/SAP	Yes	Yes	Yes	Yes	Yes	Yes
	Still Picture	Yes	Yes	Yes	Yes	Yes	Yes
Connections	Plug & Play	Yes	Yes	Yes	Yes	Yes	Yes
	EPG	No	No	No	Gemstar EPG	No	No
	Anynet	Yes	Yes	Yes	Yes	Yes	Yes
	S-Video In	Rear 2/Side 1	Rear 2/Side 1	Rear 2/Side 1	Rear 2	Rear 2	Rear 2/Side 1
	HDTV Component Video Input (Y, Pb, Pr) 1080i/480P/480i	Rear 2	Rear 2	Rear 2	Rear 2	Rear 2	Rear 2
	PC	No	No	No	No	No	No
	HDMI	Yes	Yes	Yes	Yes	Yes	Yes
Digital Sound	Optical 1	Optical 1	Optical 1	Optical 1	Optical 1	Optical 1	

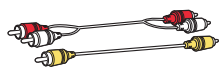
2-4 Accessories

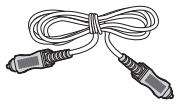
Accessories		Item	Item code	Remark
Supplied Accessories		Remocon Alkaline Battery	BP59-00084B 4301-000103	Samsung Service center
		Manual	BP68-00524A	
		ANYNET cable	BN39-00518B	
Accessories that can be purchased additionally		Video Cable / Audio Cable	-	Internal shopping mall
		Antenna Cable	-	
		Component Cable	-	
		Optical Cable	-	

MEMO

3. Alignment & Adjustment

3-1 Service Instruction

■ Check items listed after changing each

Replaced Items \ Check Items	S/W Version	Front LED	Index Delay	Actuator Gain	V-Position H-Position	CCA	Board LED	Tilt Focus
Digital Board	●(1st)		●(3rd)	●(5th)	●(2nd)	●(4th)		
Analog Board		●					●	
Power Board		●					●	
Optical Engine		●	●(3rd)	●(5th)	●(2nd)	●(4th)		●(1st)
DMD Board				●				●
Lamp		●				●		
Color Wheel						●		
Front LED Assy		●						
Actuator Subdetector Board		●						

※ If you change digital board and optical engine, check in order.
(For example, in case of "D/B", first 'S/W', second 'V/H position' and third 'Index'...)

1. Software version check :

After Entering the Service mode, Check the list below

* S/W Notation

"T_HUR3AUS5_4002" indicates "HURRICANE3 BASIC MODEL USA, ver. 4002".

T_HUR3AUS0_XXXX
200X_XX_XX
T-HURUCOM5-XXXX
T-HUR3AUS1_XXXX

2. Front LED check : See page 6-11.

3. Index Delay adjustment : See page 3-13.

4. Actuator Gain adjustment : See page 3-15.

5. Vertical / Horizontal Position adjustment : See page 3-13.

6. CCA : See page 3-14.

7. Board LED check : Check all the LED are turned on.

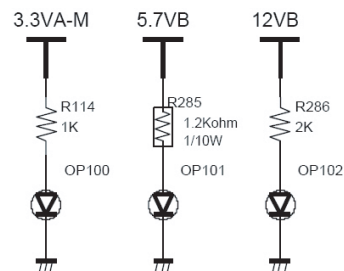

Power Check Indicator LED

8. Tilt/Focus adjustment : See page 3-17.

3-2 How to Access Service Mode

1. Turn off the power to put the unit into the STAND-BY mode.
2. In order to enter the Service Mode, Press "Mute" → "1" → "8" → "2" → "POWER" button on the Remote Control.
In case entry into SERVICE MODE is unsuccessful, repeat the procedures above.
3. Initial DISPLAY State in times of Service Mode Switch overs

```

DDP1011(L6)
DNle
ADV7401(M)
ADV7401(S)
uPD64083
MSP4440
CCA(ON)
Cinema CCA
SP Actuator
ESP
CHECKSUM      0000
OPTION
SERVICE

T_HUR3AUS0_XXXX
200X_XX_XX
T-HURUCOM5-XXXX
T-HUR3AUS1_XXXX
    
```

4. Buttons operations within Service Mode

MENU	Full Menu Display / Move to Parent Menu
Direction keys ▲ / ▼	Item Selection by Moving the Cursor
Direction keys ◀ / ▶	Data Increase/Decrease for the Selected Item
Source	Cycles through the active input source that are connected to the unit

3-3 Factory Data

★ The underlined are items applied during the service adjustment. None of the others should be adjusted.

1. DDP1011

No	Item	Range	Default	Remark
1	<u>V-Position</u>	0-60	36	Screen upper and lower adjustment
2	<u>H-Position</u>	0~120	60	Screen left and right adjustments
3	LAMP SYNC		Pulse(P)	Pulse(P), Pass(T)
4	<u>INDEX DELAY</u>	0~359	40	Synchronizes the base position of the color wheel with the corresponding color signal. This is critical to the natural color display. If the index delay is not properly set, even the correct CCA coordinates will not help when displaying natural colors.
5	SEQ SELECT	0~15	5	Sequence Selection
6	<u>V-FLIP</u>	Normal/Flip	Normal	Vertical Flip Operation
7	<u>H-FLIP</u>	Normal/Flip	Normal	Horizontal Flip Operation
8	GAMMA	0 ~ 15	2	Gamma Table Selection
9	SLR	OFF/ON	OFF	SLR Function On/Off
10	DMD_BIAS	B,C,D,E	E	DMD Bias pin voltage selection
11	Lamp Boost	0~63	20	Lamp Boost value selection
12	Lamp Sync Delay	0~4095	0	Lamp Sync delay value selection
13	Engine Select		SAMSUNG	SAMSUNG and ZEISS Selection
14	Lamp Watt		120W	120W/132W Selection
15	Lamp Select		Philips	Philips/Osram/Ushio
16	<u>Test Pattern</u>		0	This displays the built-in pattern of the DDP1011 chip. DDP1011 drives the DMD panel, so displaying this pattern means there is no error in the DDP1011 projection function and the panel itself.

2. DNle

No	Item	Range	Default	Remark
1	Test Pattern		0	Test Pattern Selection
2	NR_MAX Y/C	0~255	48	Temporal NR Gain
3	NR_MIN Y/C	0~255	16	Temporal NR Gain
4	Core	0~15	4	NEOnDCE User Set Up
5	B_RATIO		12000	Low level information for the minimum value
6	BLACK_TILT	0~255	120	Black Stretch Area
7	W_RATIO		12000	High level information for the minimum value
8	WHITE_TILT	0~255	200	White Stretch Area
9	GAIN1X	0~63	30	Gain of horizontal high frequency region
10	GAIN1Y	0~63	20	Gain of vertical high frequency region
11	GAIN2X	0~63	17	Gain of horizontal middle frequency region
12	GAIN2Y	0~63	13	Gain of vertical middle frequency region
13	GAIN3X	0~63	11	Gain of horizontal low frequency region
14	NDON		ON	ON,OFF Background Noise Detection ON/OFF Switch
15	CORING_ON		ON	ON,OFFCoring On/Off
16	SCALE_R	0~255	160	Log Mapping Gain
17	WTE_CSC		YCCRGB	YCCRGB, YPPRGB
18	DITHER_MOD		0	1,2,3
19	RED_C_COEFF		128	Gain adjustment of the contrast for the Red signal
20	GRN_C_COEFF		128	Gain adjustment of the contrast for the Green signal
21	BLU_C_COEFF		128	Gain adjustment of the contrast for the Blue signal
22	RED_B_COEFF		128	Gain adjustment of the brightness for the Red signal
23	GRN_B_COEFF		128	Gain adjustment of the brightness for the Green signal
24	BLU_B_COEFF		128	Gain adjustment of the brightness for the Blue signal
25	Sub Contrast	0~150	120	Brightness adjustment for the high-light parts of the screen
26	Sub Brightness		230	Brightness adjustment for the low-light parts of the screen
27	ALPMAU/L	0~255	50	

3. ADV7401(M)

No	Item	Range	Default	Remark
1	AUTO COLOR			Auto Color function execution
2	SOG_SYNC_LEV			Embedded Sync Trigger Level
3	AGC_TIM			AGC Time Constant Selection
4	GAIN_MAN			ON,OFF Manual Gain Control Enable
5	A_GAIN			Manual Gain Value for Channel A
6	B_GAIN			Manual Gain Value for Channel B
7	C_GAIN			Manual Gain Value for Channel C
8	A_OFFSET			Channel A Offset
9	B_OFFSET			Channel B Offset
10	C_OFFSET			Channel C Offset
11	YPM	0~7	4	Y Peaking Filter Mode
12	YSFM	0~32	1	Y Shaping Filter Mode
13	WYSFM	0~32	19	Wide Band TY Shaping Filter Mode
14	CSFM		0	C Shaping Filter Mode
15	Contrast	0~255	128	Contrast Adjust
16	Brightness	0~255	128	Brightness Adjust
17	Hue	0~255	128	Hue Adjust
18	CKILLTHR	0~7	3	Colour Kill Threshold
19	SD_OFF_Cb	0~255	128	SD Offset Cb Channel
20	SD_OFF_Cr	0~255	128	SD Offset Cr Channel
21	SD_SAT_Cb	0~255	128	Saturation Cb Channel
22	SD_SAT_Cr	0~255	128	Saturation Cr Channel
23	IFFILTSEL	0~7	3	IF Filter Select
24	LTA	0~3	0	Luma Timing Adjust
25	CTA	0~7	2	Chroma Timing Adjust
26	DNR_TH1	0~255	0	DNR Noise Threshold
27	DCT	0~3	0	Digital Clamp Timing
28	LAGC	0~7	0	Luma Automatic Gain Control
29	LAGT	0~3	3	Luma Automatic Gain Timing
30	LMG		1144	Luma Manual Gain
31	CAGC	0~7	5	Chroma Automatic Gain Control
32	CAGT	0~3	3	Chroma Automatic Gain Timing
33	CMG		2458	Chroma Manual Gain
34	CTI_AB_EN		ON	ON,OFF Chroma Transient Improvement Alpha Blend Enable
35	CTI_AB	0~3	3	Chroma Transient Improvement Alpha Blend

No	Item	Range	Default	Remark
36	CTI_C_TH	0~255	8	CTI Chroma Threshold
37	NSFSEL	0~3	0	Split Filter Selection NTSC
38	CTAPSN	0~3	2	Chroma Comb Taps NTSC
39	CCMN	0~7	0	Chroma Comb mode NTSC
40	YCMN	0~7	0	
41	HSSLICE			
42	VSSLICE			
43	DLL_PH			
44	ST_NOISE		0xFFFF	
45	ALIAS_FILTER_EN			
46	DNR_TH2		4	

4. ADV7401(S)

No	Item	Range	Default	Remark
1	AUTO COLOR			Auto Color function execution
2	SOG_SYNC_LEV	0~31	11	Embedded Sync Trigger Level
3	AGC_TIM	0~7	0	AGC Time Constant Selection
4	GAIN_MAN		ON	ON,OFF Manual Gain Control Enable
5	A_GAIN	0~1024	275	Manual Gain Value for Channel A
6	B_GAIN	0~1024	287	Manual Gain Value for Channel B
7	C_GAIN	0~1024	287	Manual Gain Value for Channel C
8	A_OFFSET	0~1024	0	Channel A Offset
9	B_OFFSET	0~1024	512	Channel B Offset
10	C_OFFSET	0~1024	512	Channel C Offset
11	YPM	0~7	4	Y Peaking Filter Mode
12	YSFM	0~32	1	Y Shaping Filter Mode
13	WYSFM	0~32	19	Wide Band TY Shaping Filter Mode
14	CSFM	(0~7)	0	C Shaping Filter Mode
15	Contrast	0~255	128	Contrast Adjust
16	Brightness	0~255	126	Brightness Adjust
17	Hue	0~255	128	Hue Adjust
18	CKILLTHR	0~7	3	Colour Kill Threshold
19	SD_OFF_Cb	0~255	128	SD Offset Cb Channel
20	SD_OFF_Cr	0~255	128	SD Offset Cr Channel
21	SD_SAT_Cb	0~255	128	Saturation Cb Channel
22	SD_SAT_Cr	0~255	128	Saturation Cr Channel
23	IFFILTSEL	0~7	3	IF Filter Select
24	LTA	0~3	0	Luma Timing Adjust
25	CTA	0~7	3	Chroma Timing Adjust
26	DNR_TH	0~255	0	DNR Noise Threshold
27	DCT	0~3	0	Digital Clamp Timing
28	LAGC	0~7	0	Luma Automatic Gain Control
29	LAGT	0~3	3	Luma Automatic Gain Timing
30	LMG	0~4096	1064	Luma Manual Gain
31	CAGC	0~7(0~3)	2	Chroma Automatic Gain Control
32	CAGT	0~3	3	Chroma Automatic Gain Timing
33	CMG	0~4096	2458	Chroma Manual Gain
34	CTI_AB_EN		ON	ON,OFF Chroma Transient Improvement Alpha Blend Enable
35	CTI_AB	0~3	3	Chroma Transient Improvement Alpha Blend

No	Item	Range	Default	Remark
36	CTI_C_TH	0~255	8	CTI Chroma Threshold
37	NSFSEL	0~3	0	Split Filter Selection NTSC
38	CTAPSN	0~3	2	Chroma Comb Taps NTSC
39	CCMN	0~7	0	Chroma Comb mode NTSC
40	YCMIN	0~7	0	
41	HSSLICE	0~3	1	
42	VSSLICE	0~3	3	
43	DLL_PH			
44	ST_NOISE		0xFFFF	

5. Upd64083

No	Item	Range	Default	Remark
1	DYCOR	0 ~ 15	2	DY detection coring level
2	DYGAIN	0 ~ 15	9	DY detection gain
3	DCCOR	0 ~ 15	3	DC detection coring level
4	DCGAIN	0 ~ 15	6	DC detection gain
5	YHCOR	0 ~ 3	1	Y output high frequency component coring
6	CDELAY	0 ~ 3	4	C signal output delay
7	YPFT		3	YPFT adjustment
8	YPPG		8	YPPG adjustment

6. MSP4440

No	Item	Range	Default	Remark
1	MDB Effect	0~127	56	Micronas Dynamic Bass
2	SRS Dialog	0~127	64	SRS Dialog clarity adjustment
3	PLL			Pilot low adjustment
4	PLH			Pilot high adjustment

7. CCA(ON)

No	Item	Range	Default	Remark
1	CCA	On/Off	On	CCA On/Off Selection
2	Red-x	0~32768	640	Red-x adjustment
3	Red-y	0~32768	340	Red-y adjustment
4	Red-Y	0~32768	86	Red-Y adjustment
5	Green-x	0~32768	300	Green-x adjustment
6	Green-y	0~32768	620	Green-y adjustment
7	Green-Y	0~32768	300	Green-Y adjustment
8	Blue-x	0~32768	150	Blue-x adjustment
9	Blue-y	0~32768	60	Blue-y adjustment
10	Blue-Y	0~32768	53	Blue-Y adjustment
11	White-x	0~32768	291	White-x adjustment
12	White-y	0~32768	300	White-y adjustment
13	White-Y	0~32768	439	White-Y adjustment
14	WB Spread			Spread CCA value to all mode
15	Move HDMI			Move to the HDMI Mode
16	DRedX			Target Red X value for CCA
17	DRedY			Target Red Y value for CCA
18	DGreenX			Target Green X value for CCA
19	DGreenY			Target Green Y value for CCA
20	DBlueX			Target Blue X value for CCA
21	DBlueY			Target Blue Y value for CCA
22	DCyanX			Target Cyan X value for CCA
23	DCyanY			Target Cyan Y value for CCA
24	DMagentaX			Target Magenta X value for CCA
25	DMagentaY			Target Magenta Y value for CCA
26	DYellowX			Target Yellow X value for CCA
27	DYellowY			Target Yellow Y value for CCA
28	D_White_X			Target White X value for CCA
29	D_White_Y			Target White Y value for CCA
30	ATV/AV/SV			

8. Cinema CCA

No	Item	Range	Default	Remark
1	DRedX		640	Target Red X value for CCA
2	DRedY		340	Target Red Y value for CCA
3	DGreenX		300	Target Green X value for CCA
4	DGreenY		620	Target Green Y value for CCA
5	DBlueX		150	Target Blue X value for CCA
6	DBlueY		60	Target Blue Y value for CCA
7	DCyanX		205	Target Cyan X value for CCA
8	DCyanY		270	Target Cyan Y value for CCA
9	DMagentaX		290	Target Magenta X value for CCA
10	DMagentaY		140	Target Magenta Y value for CCA
11	DYellowX		425	Target Yellow X value for CCA
12	DYellowY		515	Target Yellow Y value for CCA
13	D-White-X		313	Target White X value for CCA
14	D-White-Y		329	Target White Y value for CCA

9. SP Actuator

No	Item	Range	Default	Remark
1	Actuator Gain	0~175	115	Actuator Gain adjustment
2	Actuator On/Off		On	Actuator On/Off selection

10. ESP

No	Item	Range	Default	Remark
1	Dynamic Con		Off	Dynamic Contrast On/Off
2	Dynamic Strength		Medium	Low/Mid/Mas
3	Dynamic Con Gain	0~100	0	Dynamic Contrast Gain Adjustment
4	Dynamic Sat		Off	Dynamic Saturation On/Off
5	Dynamic Sat Gain	0~255	176	Dynamic Saturation Gain Adjustment
6	Sharp Picture		Off	Sharp Picture On/Off
7	Sharp Filter		HD Low	HD High/HD Low/SD Image
8	Sharp Picture Gain	0~255	176	Sharp Picture Gain Adjustment

11. CHECKSUM 0000

Excute Checksum calcaution

12. OPTION

No	Item	Range	Default	Remark
1	Lamp Clear			Initialize lamp usage time. Lamp Life is set to zero
2	User Reset			All setting is back to the default
3	WB Reset		OFF	Initialize the White Balance value
4	EER Reset			Clear the EEPROM
5	Lamp Life		0h	Lamp on time counter
6	AUTO POWER	ON/OFF	ON	The sets turns on automatically when the power cord is plugged in
7	DNle DEMO	ON/OFF	ON	DNle Demo function selection
8	Lamp Control		Dynamic	Dynamic, Always
9	MUTE TIME		600ms	Time which the screen will be black while switching channels
10	EDID WRITE			
11	DELAY MOD	ON/OFF	OFF	Sound Delay Module ON/OFF selection
12	DBG/ANY SEL	Debug/AnyNet		Select the use of the Anynet jack
13	GEM/GEMIR SEL	GemIR/Gemstar		Not used
14	226 TEST PATT			Xilleon 226 test pattern
15	Set Default Data			Initialize Service Data
16	DDC protection		OFF	DDC write ON/OFF selection
17	LNA Default		AUTO	LNA setting OFF/Auto selection
18	PROTECT		ON	Protection ON/OFF selection
19	WATCH DOG			Watch Dog ON/OFF selection
20	WD COUNT		0	Count for Watch Dog event
21	Auto Pgm Range		8	Not used
22	DIGITAL → DMD			Transfer engine adjustment data from digital to DMD
23	DMD → DIGITAL			Transfer engine adjustment data from DMD to digital

13. SERVICE

No	Item	Range	Default	Remark
1	V-Position	0 ~ 60	30	Screen upper and lower adjustment
2	H-Position	0 ~ 120	60	Screen left right adjustment
3	LAMP SYNC	Pulse/Pass	Pulse	
4	Actuator Gain		105	Actuator Gain adjustment
5	INDEX DELAY	0 ~ 1023	166	Index delay adjustment
6	AUTO COLOR		OFF	Auto Color function execution
7	CCA			CCA menu
8	Lamp Clear			Initialize Lamp usage time
9	User Reset			All setting is back to the default
10	Engine Select		SAMSUNG	SAMSUNG and ZEISS Selection
11	Lamp Watt		120W	120W/132W Selection
12	Lamp Select		Philips	Philips/Osram/Ushio

3-4 Service Adjustment

3-4-1 Vertical / Horizontal Position Adjustment

1. Turn off the power to put the unit into the STAND-BY mode.
 2. In order to enter the Service Mode, Press "Mute" → "1" → "8" → "2" → "POWER" button on the Remote Control.
 3. Select "Service" on the first display of the Service mode menu.
 4. Select the V-position for vertical positioning and H-position for horizontal positioning by using the ▲ ▼ (up, down) buttons.
- ※ Do not set the V-position value to 34 or 35. (Setting to these values will cause horizontal lines on the right side of the screen.)

3-4-2 INDEX DELAY Adjustment

1. Turn off the power to put the unit into the STAND-BY mode.
2. In order to enter the Service Mode, Press "Mute" → "1" → "8" → "2" → "POWER" button on the Remote Control.
3. Select "Service" on the first display of the Service mode menu.
4. Press the ▲ ▼ (Up or Down) button to move to INDEX DELAY, then press ENTER to select.
5. The INDEX DELAY setup screen (with a red bar at the bottom of the screen) will be displayed.
6. Press the ◀ ▶ (Left of Right) button to check the red color at the bottom of the screen at its minimum and maximum values of changing from red to magenta, then adjust to the mean value.

3-4-3 CCA Adjustment Service Methods : CCA Adjustment is needed after changing a light engine or digital board

■ CCA : In DLP TV, even the same RGB color may differ depending on the light engine. CCA (Color Coordinate Adjustment) corrects the color to achieve the color accuracy. CCA performs color correction after measuring and inputting the current light engine's data on actual color coordinates for displayed Red, Green, Blue, and White color patterns, using a color coordinate measuring equipment.

At this moment, color correction is performed on the basis of previously inputted Desired Color Coordinates and Measured Color Coordinates. Measured Data on Service Engine's color coordinates is presented on the CCA label. Input the label values to perform CCA color correction.

1. Condition of the CCA Label upon Receipt of the Service Engine

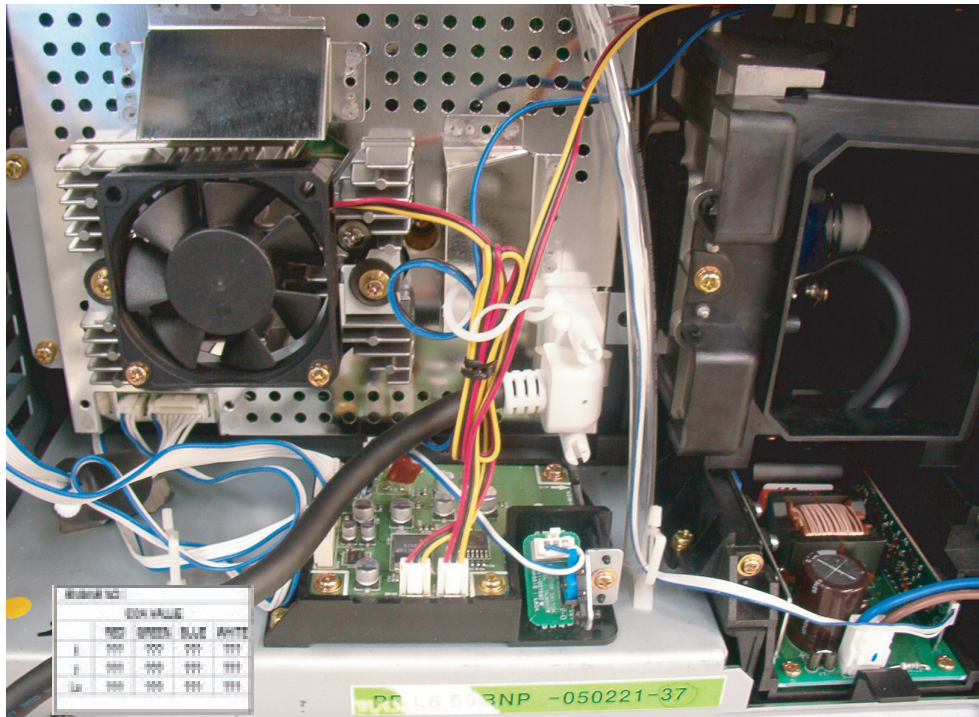

* "CCA LABEL" describes the measured color coordinates on the light engine.

2. CCA Service Procedures

To execute CCA adjustment , perform the following steps :

- 1) Turn off the power to put the unit into the STAND-BY mode.
- 2) In order to enter the Service Mode, Press "Mute" → "1" → "8" → "2" → "POWER" button on the Remote Control.
- 3) From the Factory Service Mode Menu; select SERVICE > CCA.
- 4) Switch the CCA OFF.
- 5) Enter the CCA Red, Green, Blue and White basic engine data to the DLP.
- 6) Input the D-White-x, y values in the coordinates per destination. (if necessary)
- 7) Select WB SPREAD, then press Enter to activate the WB Spread SET ensuring that you adjust until you get the OK sign. After adjusting, exit Factory Mode.
- 8) When the adjustment is complete, check the picture quality.

*** Attention**

Performing CCA is independent on current display's resolution and input signal type if you don't measure color coordinates data.

Measuring color coordinates data requires specific equipment not possessed by service personnel, that makes performing manual adjustment impossible. Adjusting CCA is applied to all the signal mode. Don't change Desired value because it will be harmful to the color of the SET.

CCA Menu in FACTORY Mode

```

CCA ON/OFF
Red - x : ???
Red - y : ???
Red - Y : ???
Green - x : ???
Green - y : ???
Green - Y : ???
Blue - x : ???
Blue - y : ???
Blue - Y : ???
White - x : ???
White - y : ???
White - Y : ???
WB SPREAD
Move HDMI
    
```

3-4-4 ACTUATOR GAIN Adjustment

1. Before Adjustment

- 1) Turn off the power to put the unit into the STAND-BY mode.
- 2) In order to enter the Service Mode, Press "Mute" → "1" → "8" → "2" → "POWER" button on the Remote Control.
- 3) Select "Service" on the first display of the Service mode menu.
- 4) Press the ▲ ▼ (Up or Down) button to move to ACTUATOR GAIN, then press ENTER to select.

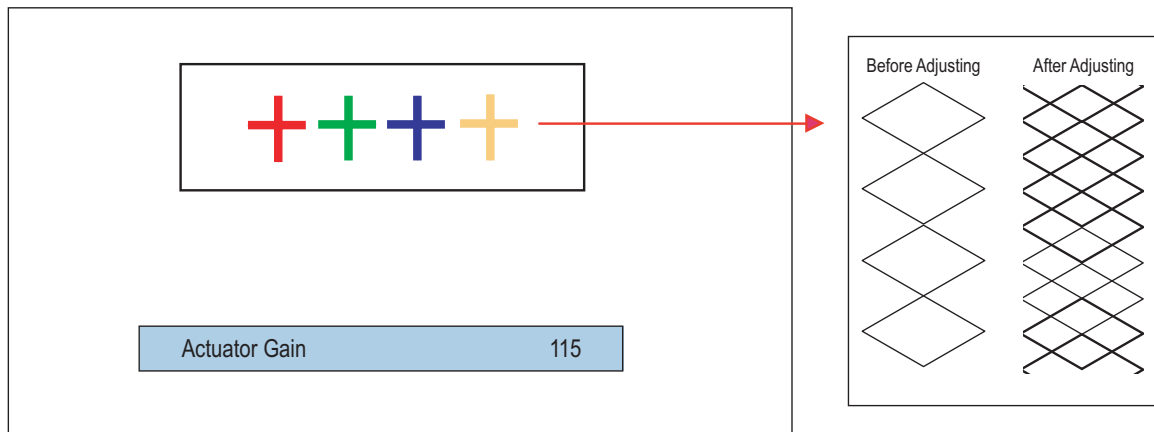

2. Making Adjustments

- 1) As shown in the picture above, change the actuator values to eliminate saw tooth shapes.
 - To fine tune, increase the data value ensuring that you get the center between the starting and ending points of the disappearing saw tooth shape.

3-5 Software Upgrade

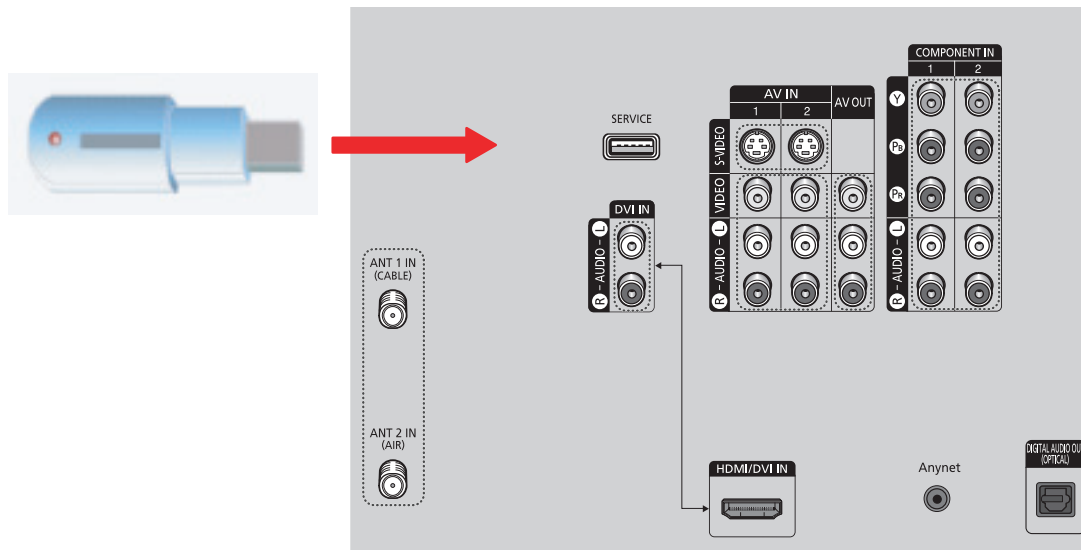

1. Prepare the USB memory stick with the built-in firmware.
2. While the TV is off, insert the USB stick into the SERVICE terminal.
3. When turning on the TV, there should be a long beeping tone and the firmware download process should start. If there is no sound from the TV, turn it off and then on again.
4. When the download is complete, there will be another long beeping tone and the TV will go into standby mode.

※ Check for the Firmware Version

- 1) Turn off the power to put the unit into the STAND-BY mode.
- 2) In order to enter the Service Mode, Press "Mute" → "1" → "8" → "2" → "POWER" buttons on the Remote Control.
- 3) In case entry into SERVICE MODE is unsuccessful, repeat steps 1 and 2 directly above.
- 4) You can check the firmware version at the bottom of the Factory menu.

T_HUR3AUS0_XXXX
 200X_XX_XX
 T-HURUCOM5-XXXX
 T-HUR3AUS1_XXXX

3-6 Replacements & Calibration

3-6-1 Tilt the Screen

1. Remove the 14 point screws. Remove the Bottom cover.
Fix the safety switch on the right with tape so that the set can be turned on after removing the bottom cover.
: TH,B,M4.L15,BLK,SWRCH18A



2. Remove the 3 points screws.
 - * Left 2 points screws
: PWH,S,M3,L8,ZPC(YEL),SWRCH18A
 - * Right 1 points screw
: PWH,S,M3,L7,ZPC(YEL),SWRCH18A

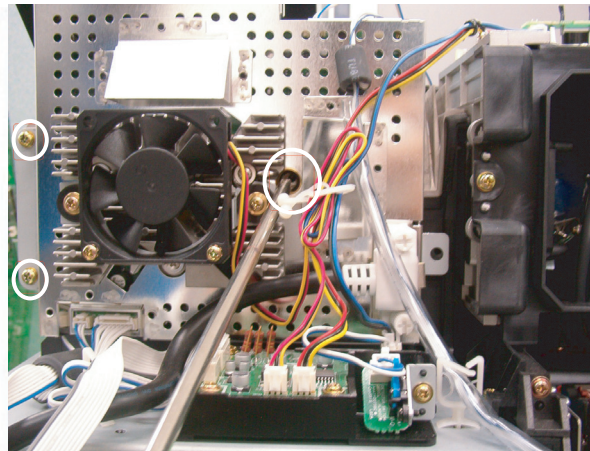

3. Turn off the power to put the unit into the STAND-BY mode.
In order to enter the Service Mode, Press "Mute" → "1" → "8" → "2" → "POWER" button on the Remote Control.
Select "DDP1011(L6)" on the first display of the Service Mode menu. Press the ▲ ▼ (Up or Down) button to move to TEST PATTERN, then press ENTER to select. Press the ► (Right) button until you see CROSSHATCH PATTERN.
Then, adjust the screen position, by holding both of the upper corners of the DMD board.

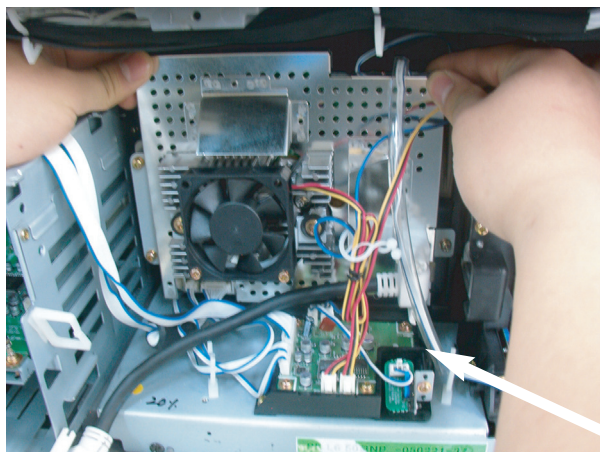

CROSSHATCH PATTERN

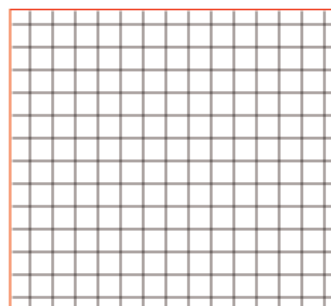

Fix the safety switch on the right with tape so that the set can be turned on after removing the bottom cover.

- ※ Even when those screws are removed, the board does not separate it can be moved within the adjustable range because there is a spring screw at the center that holds it.
- ※ When adjusting the screen, it is better for two people to work together.
One person should adjust the picture position while the other person looks at the screen.
- ※ The movement direction of the board and the picture are opposite.
 - When the board is lifted upward, the screen descends down.
 - When it is tilted to the left, the screen tilts to the right.
- ※ When the picture adjustment is completed:
First, tighten the two screws on the left of the DMD board and then slowly tighten the one screw on the bottom right.
Be careful not to touch the board while tightening the screws.
(When using an electric-powered screwdriver, be careful that the torque is not too high.)

3-6-2 Align the Focus

1. Loosen and remove the 6 screws on the terminal board and jack.
: TH,B,M4.L15,BLK,SWRCH18A

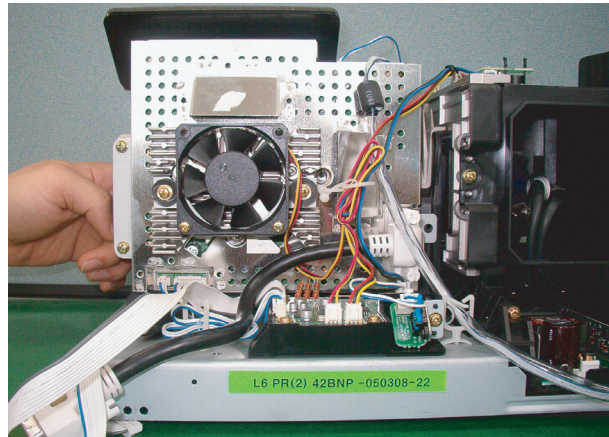
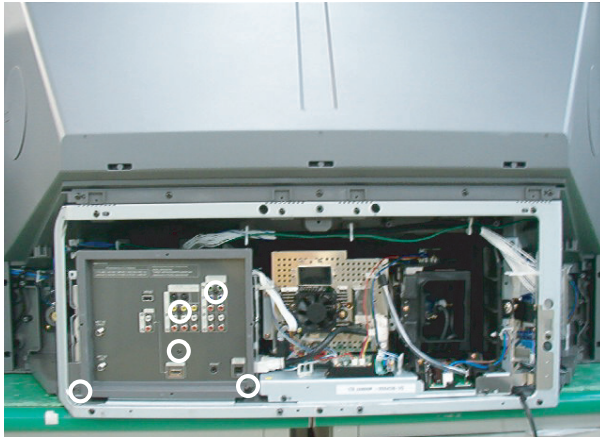

2. It is not necessary that engine assy separate to adjust focus.
You put your hand in set below diagram. Move the focus alignment dial of Projection lens to the clockwise or counter clockwise until the picture is clear displayed. You are easy to work together another service man.

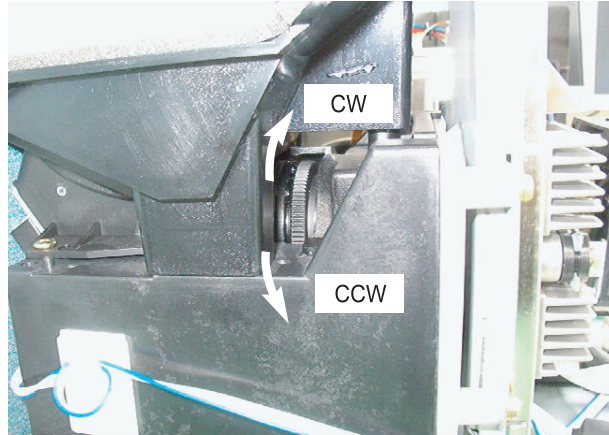
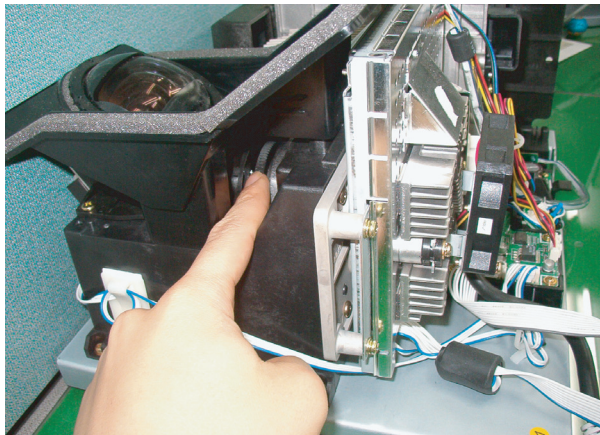

5. Electrical Part List

5-1 SP42L6HNX/XAX Service Item

You can search for the updated part code through ITSELF web site.

URL:<http://itself.sec.samsung.co.kr>

Loc.No.	Code No.	Description	Specification	Q'ty	SA/SNA	Remark
T0245	BN39-00164D	LEAD CONNECTOR-ASSY	HURRICANE,UL1015#18,	1	S.A	
T0128	BN39-00518B	CBF SIGNAL-STEREO	SVP-50L3HR,1P,UL2464#2	1	S.A	
3-2P_LC	BP39-00026E	LEAD CONNECTOR-COVER DETECT	HLP5063WX,U	1	S.A	
M0013	BP96-00938C	ASSY COVER P-REAR BOTTOM	L6,HIPS V0,GR50	1	S.A	
M0018	BP97-00980A	ASSY MICOM	T-HUR3AUSO-1007_NOR,L63C,49BV	1	S.A	
M0018	BP97-00981A	ASSY MICOM	T-HUR3AUSO-1007_NAND,L63C,KFG	1	S.A	
M0125	BP39-00106C	CBF SIGNAL-DVI(D)	HLP5063WX,24P/24P,2027	1	S.A	
M2893	BP39-00030A	LEAD CONNECTOR	L62A/HLM507W,UL1061#28,UL	1	S.A	
M2893	BP39-00043A	LEAD CONNECTOR	L62A/HLM507W,UL1007#22,UL	1	S.A	
M2893	BP39-00043A	LEAD CONNECTOR	L62A/HLM507W,UL1007#22,UL	1	S.A	
M2893	BP39-00096B	LEAD CONNECTOR	HLN507W,UL2547#26,UL/CSA,	1	S.A	
M2893	BP39-00103A	LEAD CONNECTOR	HLN507WX,UL2464 #26,UL/CS	1	S.A	
M2893	BP39-00108A	LEAD CONNECTOR	HLN507WX,UL1007#26,UL/CSA	1	S.A	
M2893	BP39-00140A	LEAD CONNECTOR	HLP5063WX,UL2547#26,3P,40	1	S.A	
M2893	BP39-00141A	LEAD CONNECTOR	HLP5063WX,UL1617#22,UL/CS	1	S.A	
M2893	BP39-00146A	LEAD CONNECTOR	HLP5063W,UL1185#26,UL,30P	1	S.A	
M2893	BP39-00147A	LEAD CONNECTOR	HLP5063W,UL1007#26,UL/CSA	1	S.A	
M2893	BP39-00148B	LEAD CONNECTOR	HLP5085WX,UL1007#26,10P,5	1	S.A	
M2893	BP39-00174A	LEAD CONNECTOR	SVP-50L3HD,UL1007#22,UL/C	1	S.A	
M2893	BP39-00175A	LEAD CONNECTOR	HLP5067WX,UL1007#26,UL/CS	2	S.A	
M2893	BP39-00176B	LEAD CONNECTOR	HLR5067WX,UL1617#22,1P,80	1	S.A	
M2893	BP39-00191A	LEAD CONNECTOR	HLR5667W,UL1571#30,5p,350	1	S.A	
M2893	BP39-00208A	LEAD CONNECTOR	SVP-42L6HDL,UL1007#26,UL/	1	S.A	
T0003	BP96-01012G	ASSY COVER P-FRONT	42L6,XAX(L64C),HIPS,H	1	S.A	
T0030	BP96-01015A	ASSY COVER P-SIDE	42L6,HIPS HB,GR503,LEF	1	S.A	
T0030	BP96-01016A	ASSY COVER P-SIDE	42L6,HIPS HB,GR503,RIG	1	S.A	
T0049	BP47-00012A	LAMP-BALLAST	0.4A,135W,380V DC	1	S.A	
T0074	BP59-00084B	REMOCON	HURRICANE,TM76,200*54*30,ZILOG M	1	S.A	
T0091	BP94-02059C	ASSY PCB MISC-A/V SIDE	HLR5067,L64B,L6	1	S.A	
T0120	BP94-02222N	ASSY PCB POWER	SP42L6/XAX,L64C(L6),ATSC,	1	S.A	
T0129	BP96-01018T	ASSY ENGINE P-DLP	42L6(L620),OSRAM 120W,	1	S.A	
T0132	BP94-02233A	ASSY PCB MISC-DIGITAL	HURRICANE3,L64C,AT	1	S.A	
T0145	BP94-02232A	ASSY PCB MISC-ANALOG	HLR5056W,L64C,USA,L	1	S.A	
T0158	BP96-00937C	ASSY COVER P-MAIN	L6,M62A,HIPS, V0,GR503	1	S.A	
T0245	BP39-00044B	LEAD CONNECTOR-ASSY	HURRICANE,UL1007#22,	1	S.A	
T0245	BP94-02140D	ASSY PCB MISC-KEY CONTROL	HLP5063W,L62B,	1	S.A	
T0286	BP31-00010B	FAN-DC	SVP-50L7XHD,UL94V-0, PBT,Wire Len	1	S.A	
T0286	BP31-00011A	FAN-DC	AD0612LB-D72GL,P.B.T UL94-Vo,Wire	1	S.A	
T0703	BP96-01102B	ASSY DMD BOARD P	L6 Osrsm E22,DMD BOARD,	1	S.A	
T0888	BP96-01394A	ASSY LAMP P	L620,OSRAM 120W,E22,50L4(AKA	1	S.A	
T0889	BP96-01103A	ASSY COLOR WHEEL P	L6,SERVICE	1	S.A	
T0952	BP59-00090A	MODULE-RF SPLITTER	,UMX-NT-046,2INPUT 10	1	S.A	

MEMO

6. Troubleshooting

6-1 Checkpoints by Error Mode

- 1. Power Light: Check the master switch (ON/OFF) and the fuse to see if they are operating.
- 2. LED Blinking: See the basic LED checklist in 6-2-1

< Blinking Temp & Timer LED >

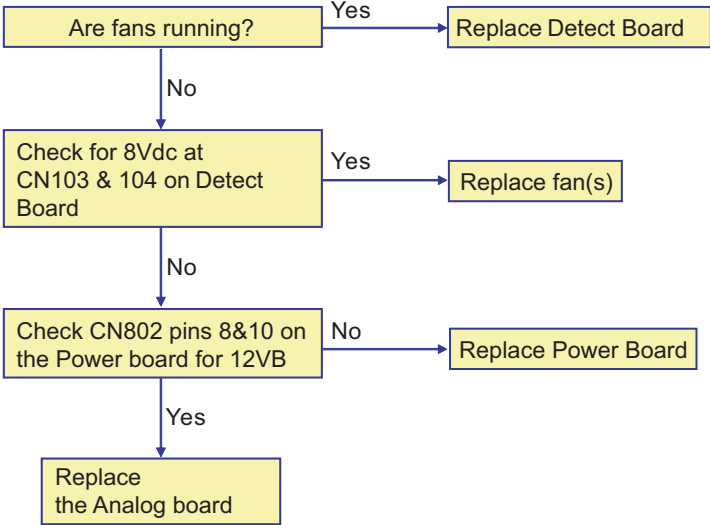

< Blinking Lamp and Temp LEDs >

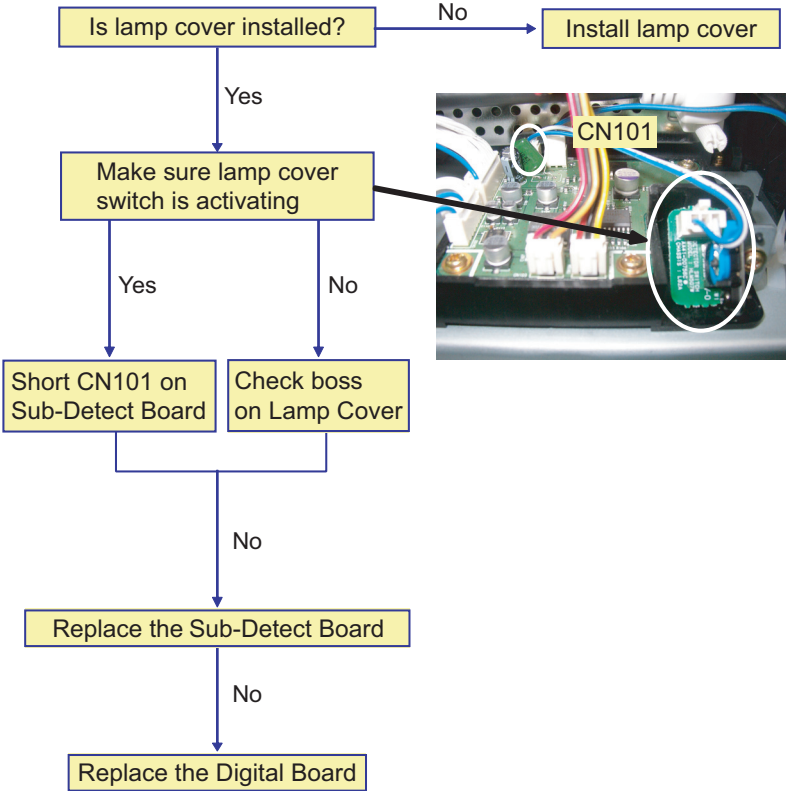

< Blinking Temp LED >

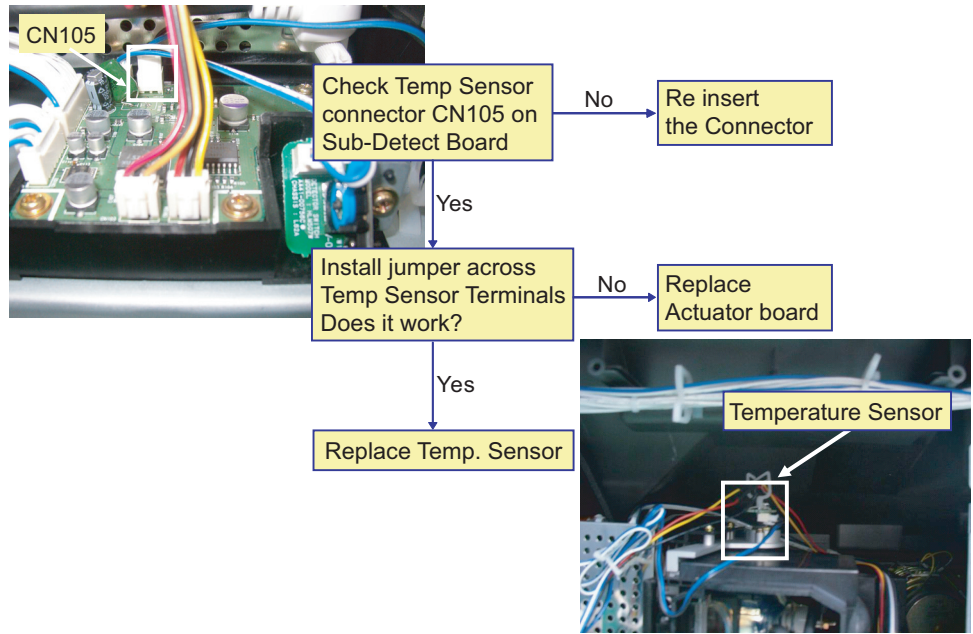

A blinking lamp LED is the most common failure indication. It can be caused by no lamp, no color wheel, no fan(s), or other defective components.

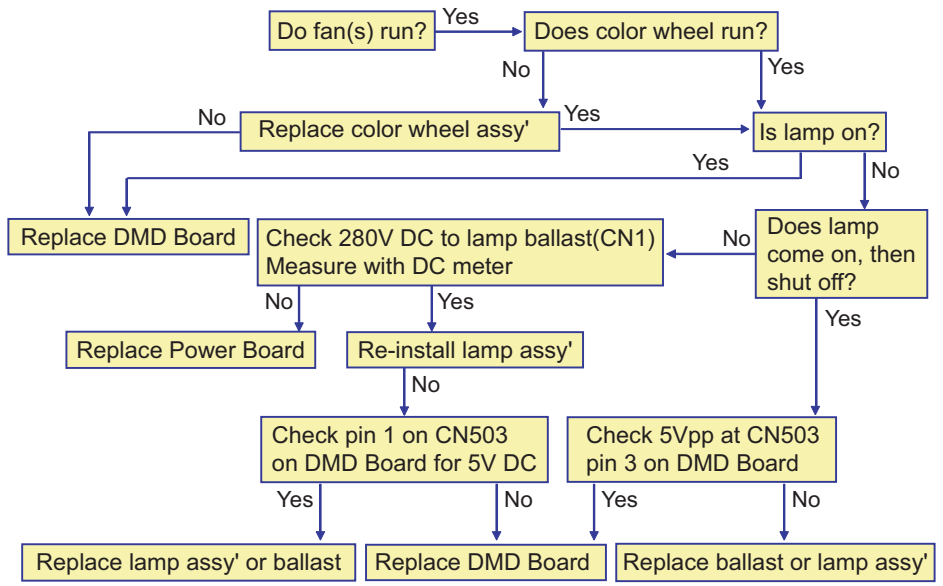

3. Noise:

Internal noise may be caused by a foreign substance on the fan or driving device.

For a DLP TV, the lamp fan, DMD board fan and color wheel are vulnerable to noise. Sometimes the connector wire around the lamp or DMD fan makes contact with the fan, while the color wheel is protected inside the module and cannot make contact with any nearby wires. However the color wheel sensor or the drive motor may cause noise by making contact with the color wheel.

As the color wheel uses an air bearing system, it has a very slight possibility of creating internal noise.

Sometimes outworn transistors may cause noise when regular noise occurs for other reasons than the fan itself. When irregular noise occurs for no particular reason, check the inside of the TV for any foreign substances.

The DLP projection TV may cause noise as the physical screen is empty inside, causing a resonance to a particular frequency. Thus a low vibration is not a malfunction.

Any 'creaking' noise is mostly from the structure of the device itself. A short, harsh noise may occur from a distortion or malformation due to thermal expansion between the metal joints, screws and loaded parts, respectively. Any intermittent 'creaking' noise can be removed by loosening the screws.

4. Black Screen (Voice Output):

Check the lamp/ballast of the replacement and, if there is nothing wrong, check the array resistance RA701-RA704 for the wave form or look into the connector joint areas as described in the manual (p.6-1).

When the measurement is not +/- 25v, DDP1011 is in error. In conclusion, you should replace the DMD board.

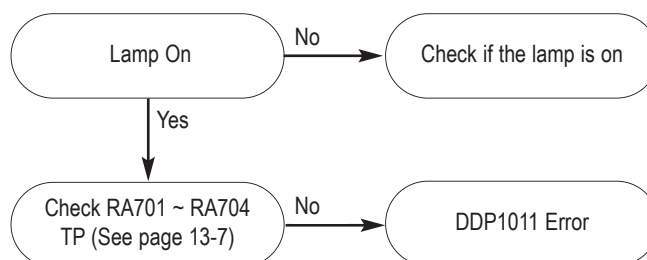

5. A black screen with the lamp on: Replace the DMD board.

6. Line Pattern: Regular line patterns occur vertically or horizontally: Replace the DMD board.

7. Voice Distortion: Replace the analog board.

8. Outside Light: This is not a product malfunction, but a possible installation or human error. This occurs when the projected light from the surrounding illumination reflects onto the screen. This disappears as the TV starts operating and the TV lamp gets brighter. However, you can avoid outside light by changing the position of the TV or the installation angle. Decreasing the illumination or changing the indoor lighting may work.

9. Screen Flip-over:

Enter Factory mode in DDP1011 and perform H-Flip (flip horizontally) and V-Flip (flip vertically).

The screen will flip over horizontally or vertically.

10. Other Screen Errors:



- ▶ 40 Vertical lines 16 pixels wide:
DDP1011 or BGA, DMD panel interference.
→ Replace the DMD board

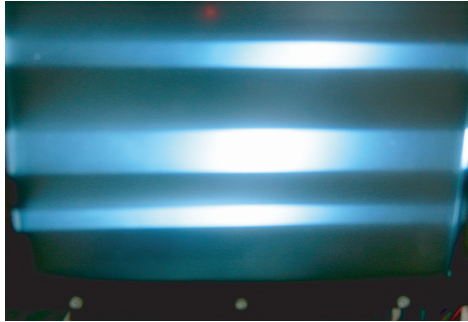

- ▶ Horizontal Bar or No Raster:
Error in DDP1011 or the DMP panel.
→ Replace the DMD board



- ▶ Dotted Vertical Bar:
Error in Rambus Dram(IC 403) or the soldering
→ Replace the DMD board

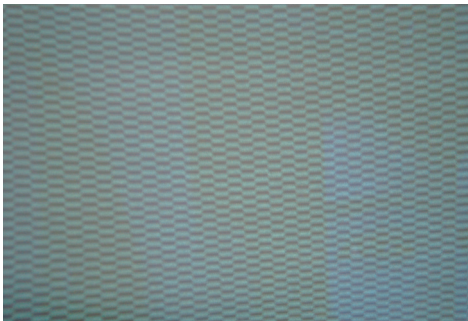

- ▶ Beehive mosaic patterns all over the screen:
Error in the LVDS Receiver (IC 601) or the soldering
The H sync signals are not transferred to DDP1011.
→ Replace the DMD board.

6-1-1 Video Circuit Error Checking

■ Basics:

- The DDP1011 on the DMD board has a feature to display internal test patterns.
- DN1e, which is an end port in the digital board, has a feature to display internal test patterns.
- The analog board sends signals to ADV7401 on the digital board.
- The analog board is the first output and the digital board is the second one, followed by DMD, which is the final one.

■ Diagnosis By Module

1. Access Service Mode

(In Standby mode, press "Mute", "1", "8", "2" and "Power" to turn the screen on and enter service mode)

2. Check if there is an error in the DMD board

DDP1011 → TEST PATTERN → Press the right arrow key:

Options of FULL WHITE, BLACK, RED, GREEN and BLUE PATTERN are displayed on the screen.

If "Pattern" does not appear, this is a DMD board error.

3. Check if there is an error in the digital board before the DMD.

When the DMD board has been determined to be error free based on the test patterns:

FACTORY MODE → DN1e → TEST PATTERN normal display: no error in the digital board.

If "Pattern" does not appear, it may be from a DMD board or ATI error or there is an analog board malfunction.

4. Check if there is an error in the analog board.

Check for a power signal from the analog to the digital boards. (See the circuit diagram below).

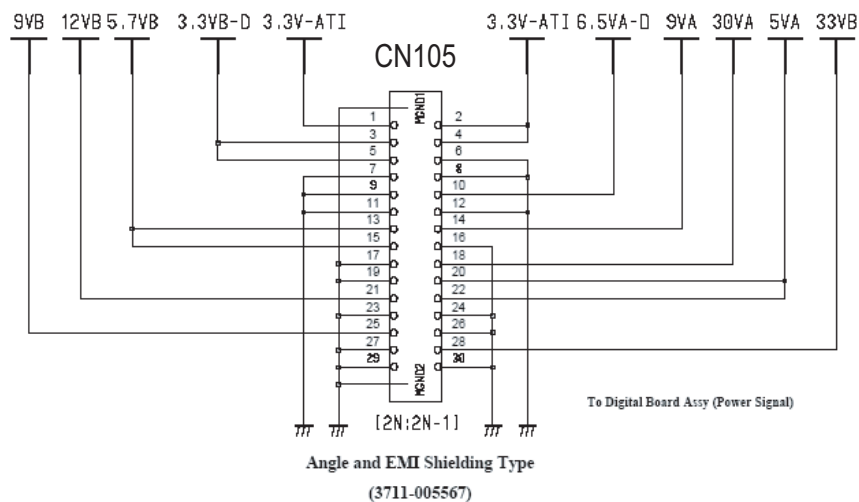

6-1-2 Flow Chart for Malfunction

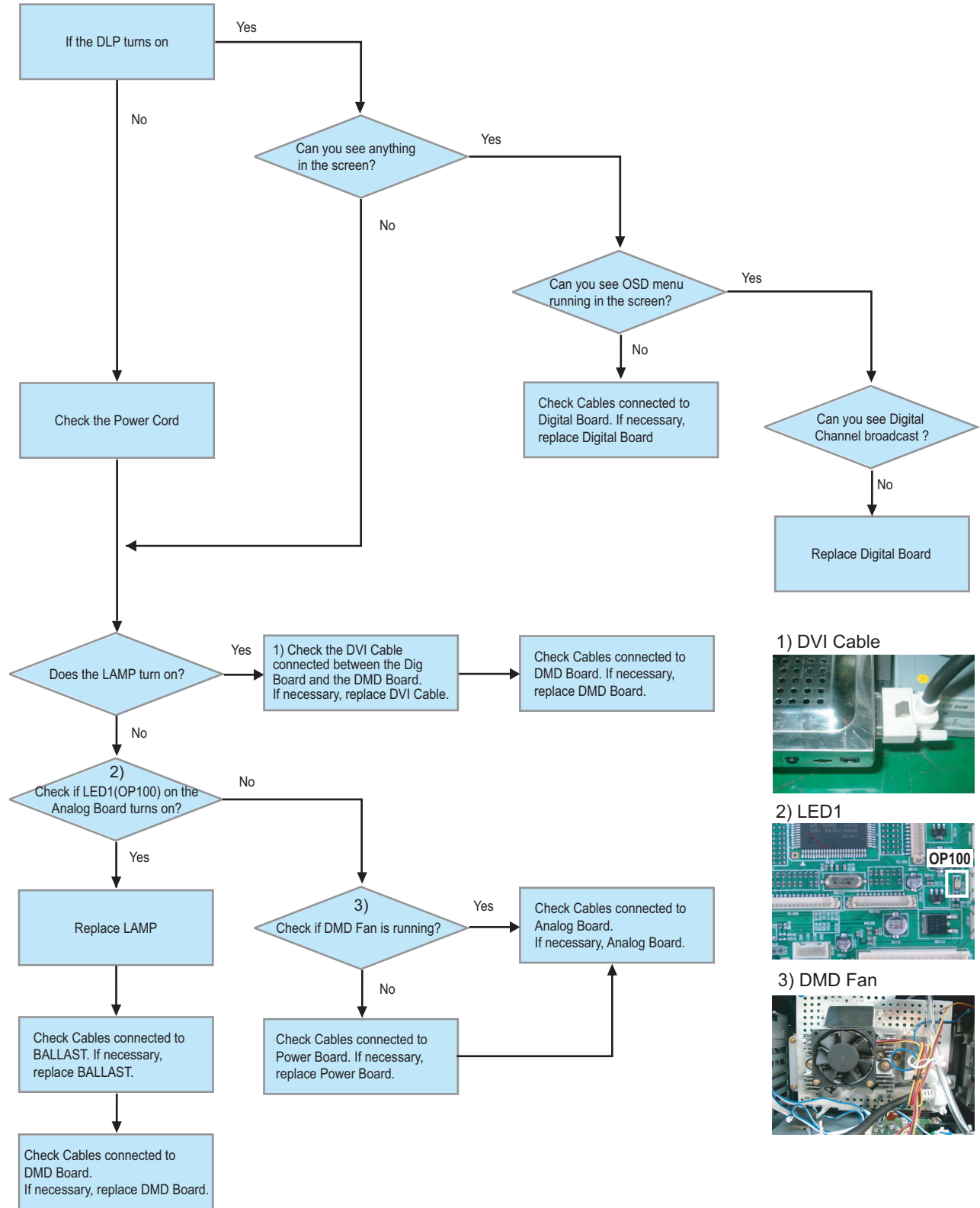

1) DVI Cable

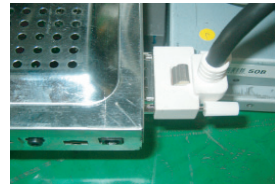

2) LED1

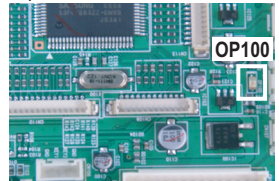

3) DMD Fan

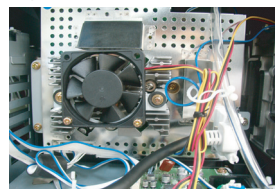

6-2 Troubleshooting Procedures by Error Modes

6-2-1 Installation & Connection

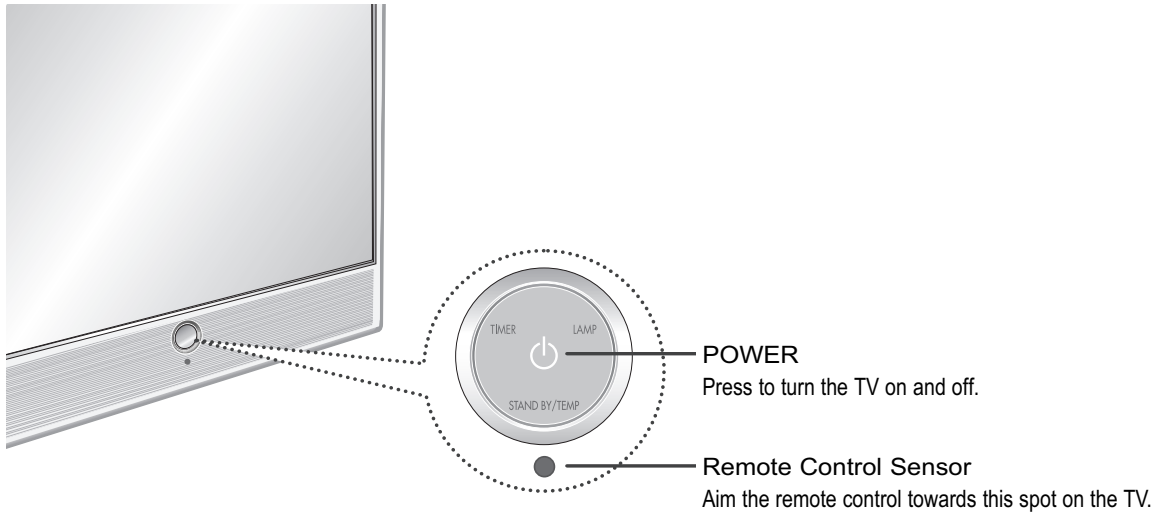

- : Light is On
- ◐ : Light is Blinking
- : Light is Off

TIMER	LAMP	STAND BY/TEMP	Indication
○	○	●	Standby state.
○	◐	○	The picture will automatically appear in about 15 seconds.
●	◐	○	Auto Timer ON/OFF has been set and the set will automatically be turned on in about 25 seconds.
◐	○	◐	A cooling fan inside the set is not operating normally.
○	◐	◐	Lamp cover on rear of the set is not properly shut.
○	○	◐	Check if the ventilation hole on the rear of the set is blocked, because if the inner temperature is too high, the power will shut off.
◐	◐	◐	Lamp may be defective.

- * It takes about 30 seconds for the TV to warm up, so normal brightness may not appear immediately.
- * The TV has a fan to keep the inside lamp from overheating. You'll occasionally hear it working.

6-2-2 Protect Status

1. When the rear cover is opened

A sensor detects when the rear cover is opened and turns the set off and then into Standby mode.

If you close the cover or fix the switch, you can turn the set on by pressing the Power button on the unit or the remote control.

The set will then operate normally.

2. When the temperature sensor operates

When the set is overheated, the internal temperature sensor turns the set off and the set goes to Standby mode.

When the internal temperature of the set returns to a normal range, turn the power on by pressing the Power button on the unit or the remote control. The set will then operate normally.

3. Attempting to turn the lamp on fails repeatedly

If turning the lamp on fails, the set automatically tries turning the lamp on 3 times. If all attempts fail, all LED's on the front panel will blink. Check the lamp and the ballast and replace them, if necessary.

6-2-3 Troubleshooting by the Checksum

Using Checksum to determine an error is neither reliable nor convenient.

The checksum can only be used effectively during a S/W service repair.

The checksum will be the same if the S/W version loaded into the TV is the same.

As programs of the same version have the same checksum value, you can determine if the program has been properly downloaded if you know the checksum of the version.

The following is required:

Factory Mode → Checksum → right button → checksum calculation → checksum output (ex: 0xab2b)

■ Examples

T_ROBOAKR1_1010 : Checksum = 0xab2b

T_ROBOAKR1_1014 : Checksum = 0x4faa

6-3 Troubleshooting Procedures by ASS'Y

6-3-1 Check Lamp & Ballast

1. When the lamp is not on, check if there is anything wrong with the ballast.

Remove the lamp. Fix the safety switch on the right with tape and turn on the power. Check to see if a blue flame starts igniting in the arc gap inside the ballast momentarily during start-up. There is no problem with the ballast if there is a flame. When the ballast has no error, replace the lamp.

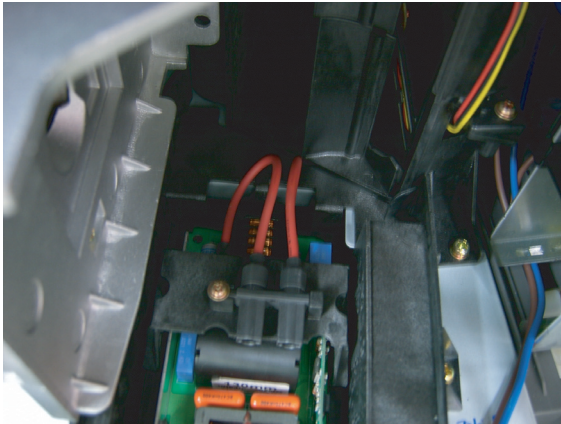

A blue flame occurs momentarily during start-up.

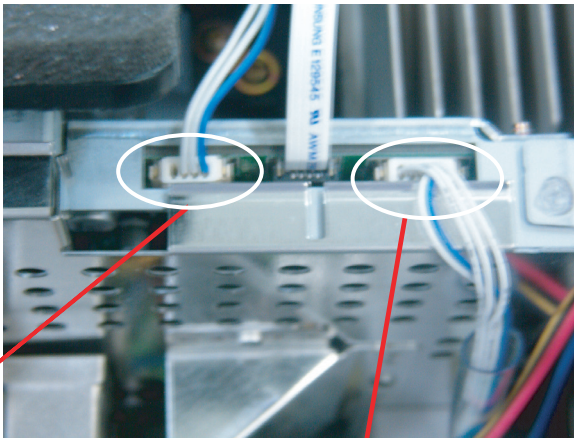
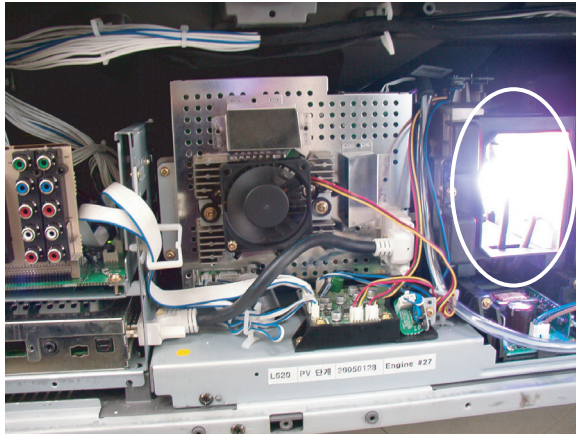
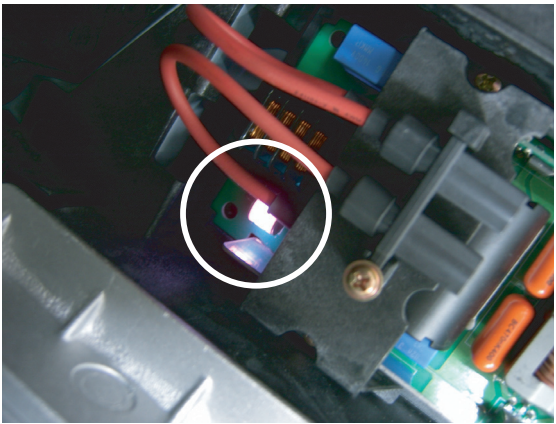

3.5V 180Hz

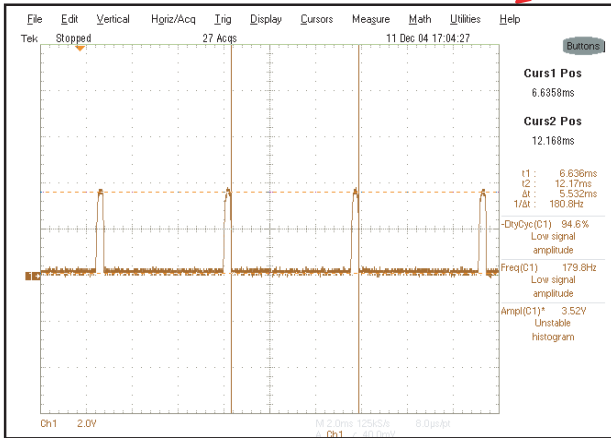

5V 180Hz

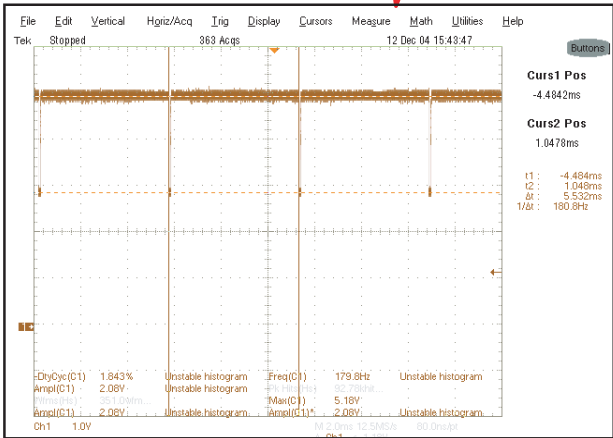

6-3-2 When the lamp and the ballast are normal but the lamp does not turn on or turns off right after quickly lighting up

1. Check the color wheel

Check if the color wheel is running. + Check the DMD board and the ballast for the signals.

Check the second CN503 pin for input signals. When 3.5V, 180Hz is output, the color wheel is operating normally.

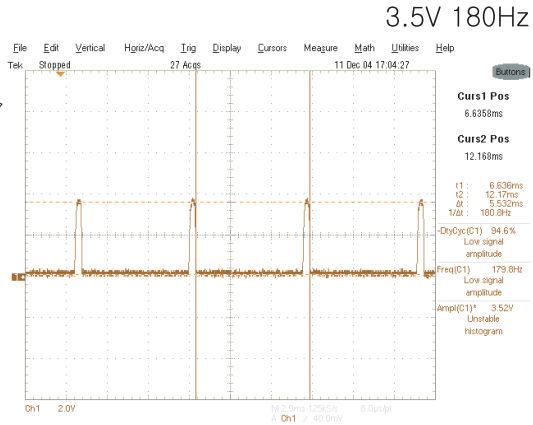
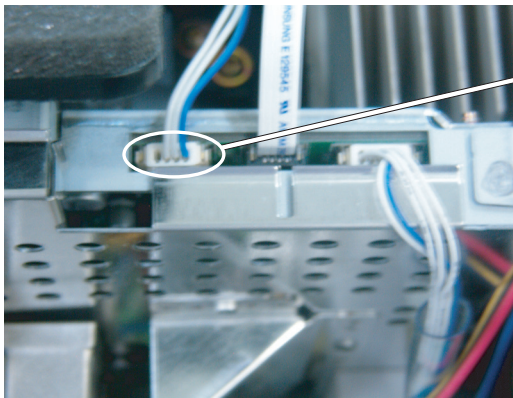
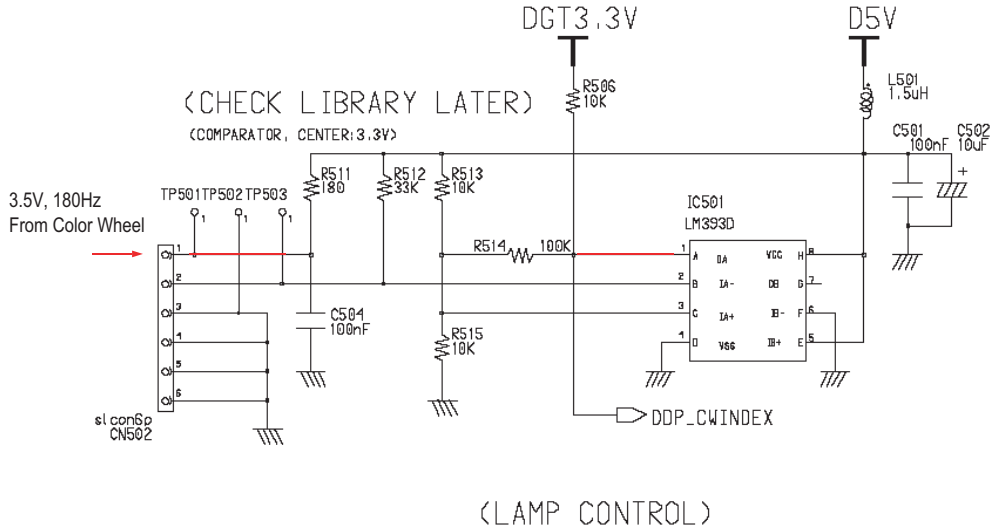

※ DMD Board Check Diagram

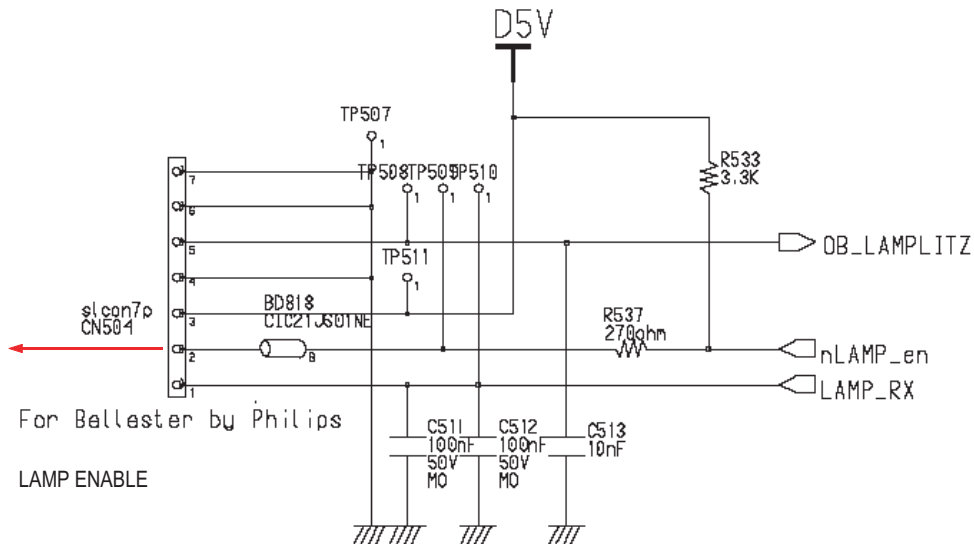

6-3-3 DDP1011 Electronics Debugging Flow Diagram

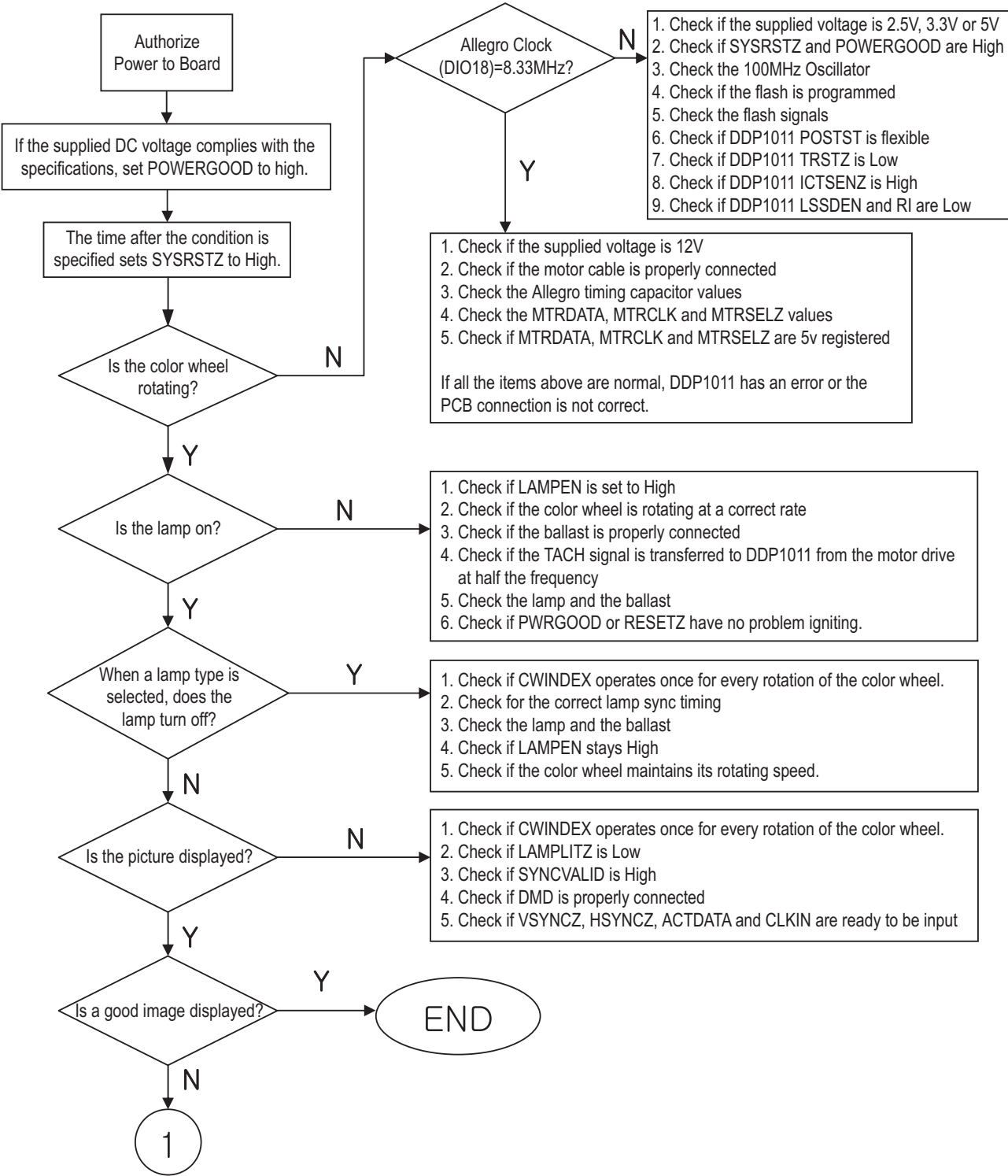

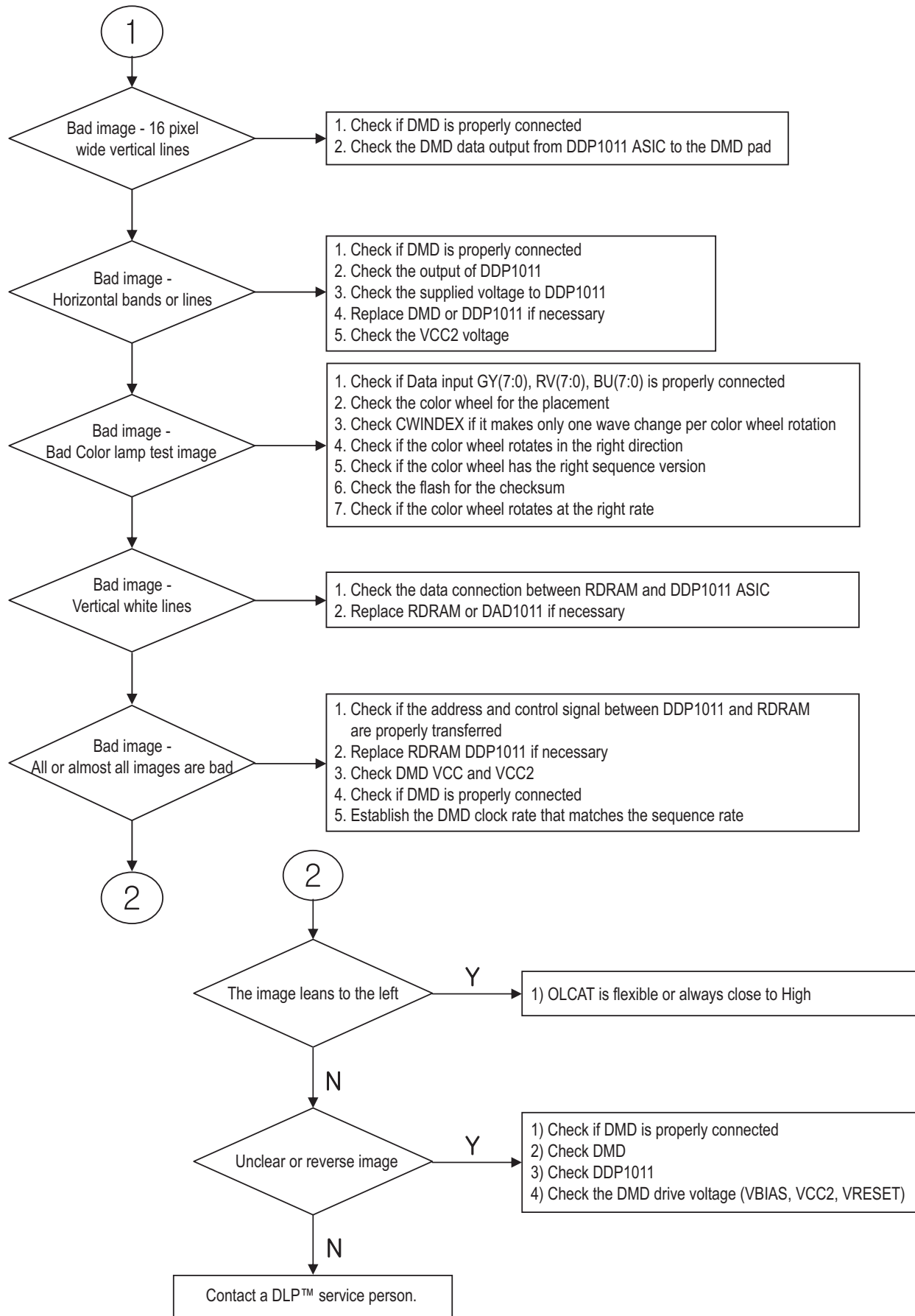

7. Block Diagram

7-1 Overall Block Diagram

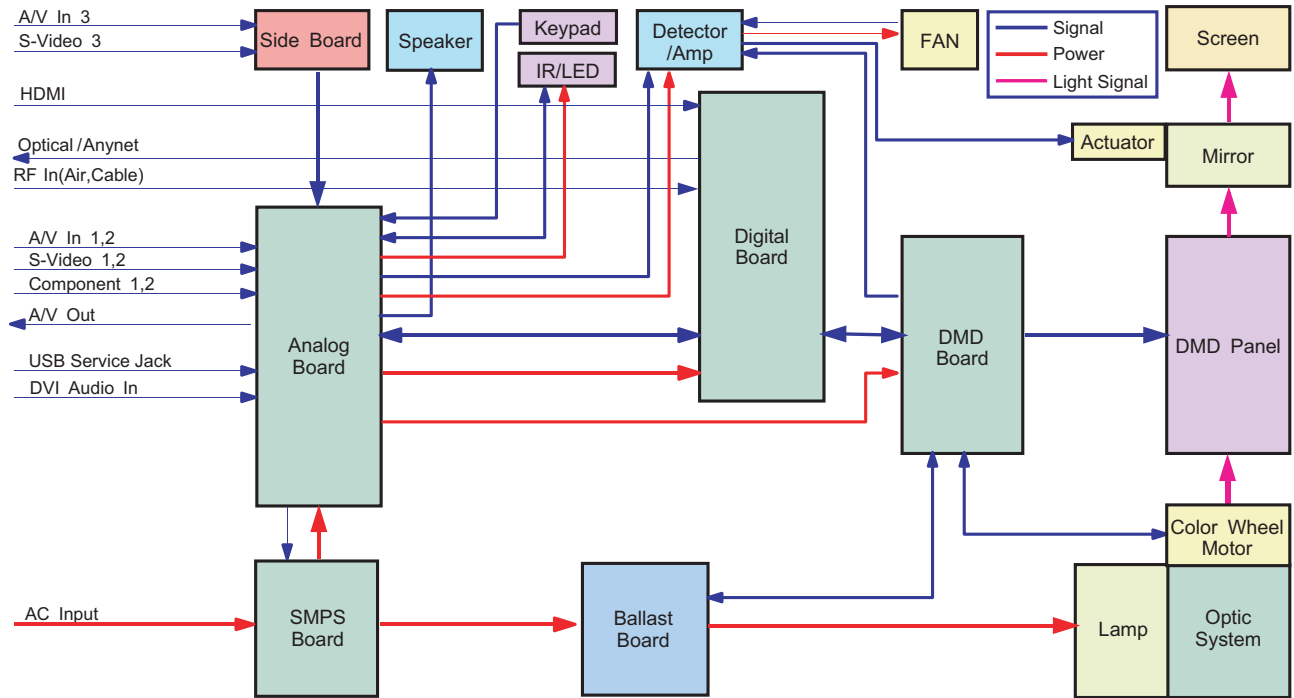

7-2 Partial Block Diagram

7-2-1 SMPS Block Diagram

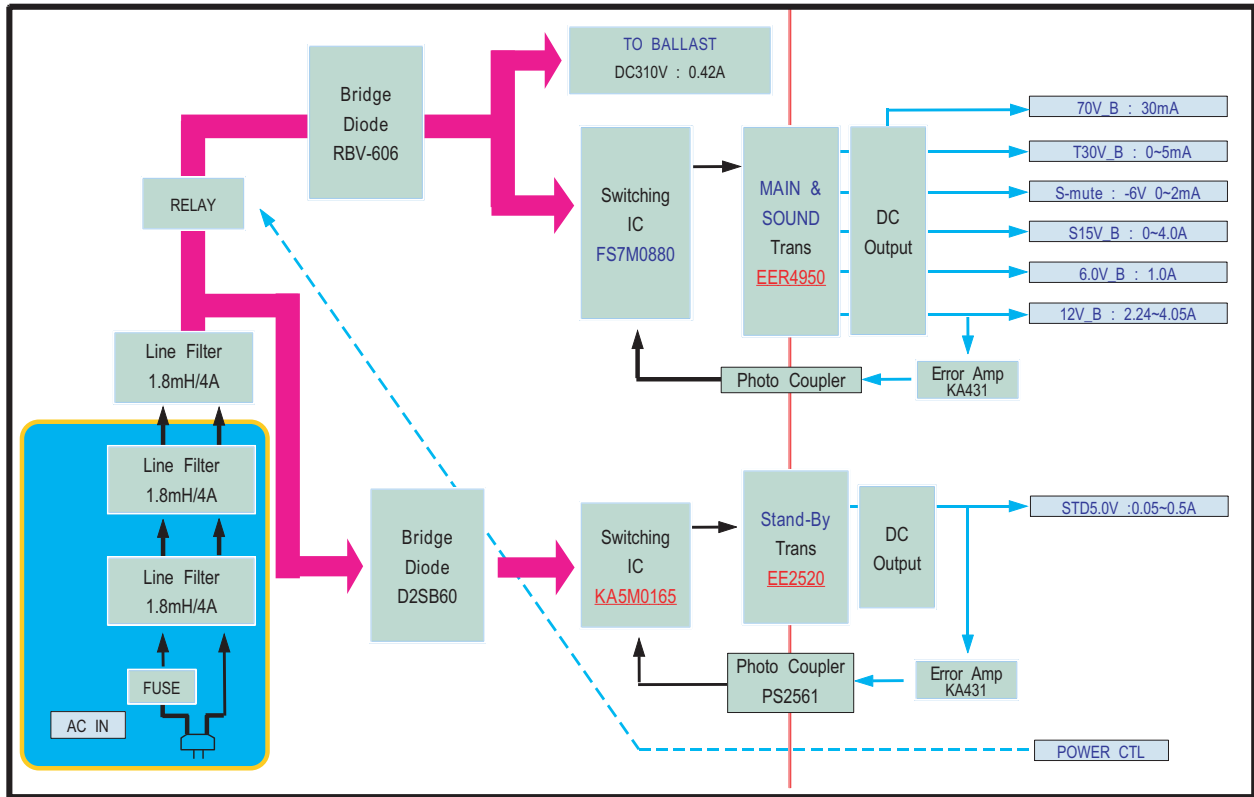

7-2-2 Digital Block Diagram

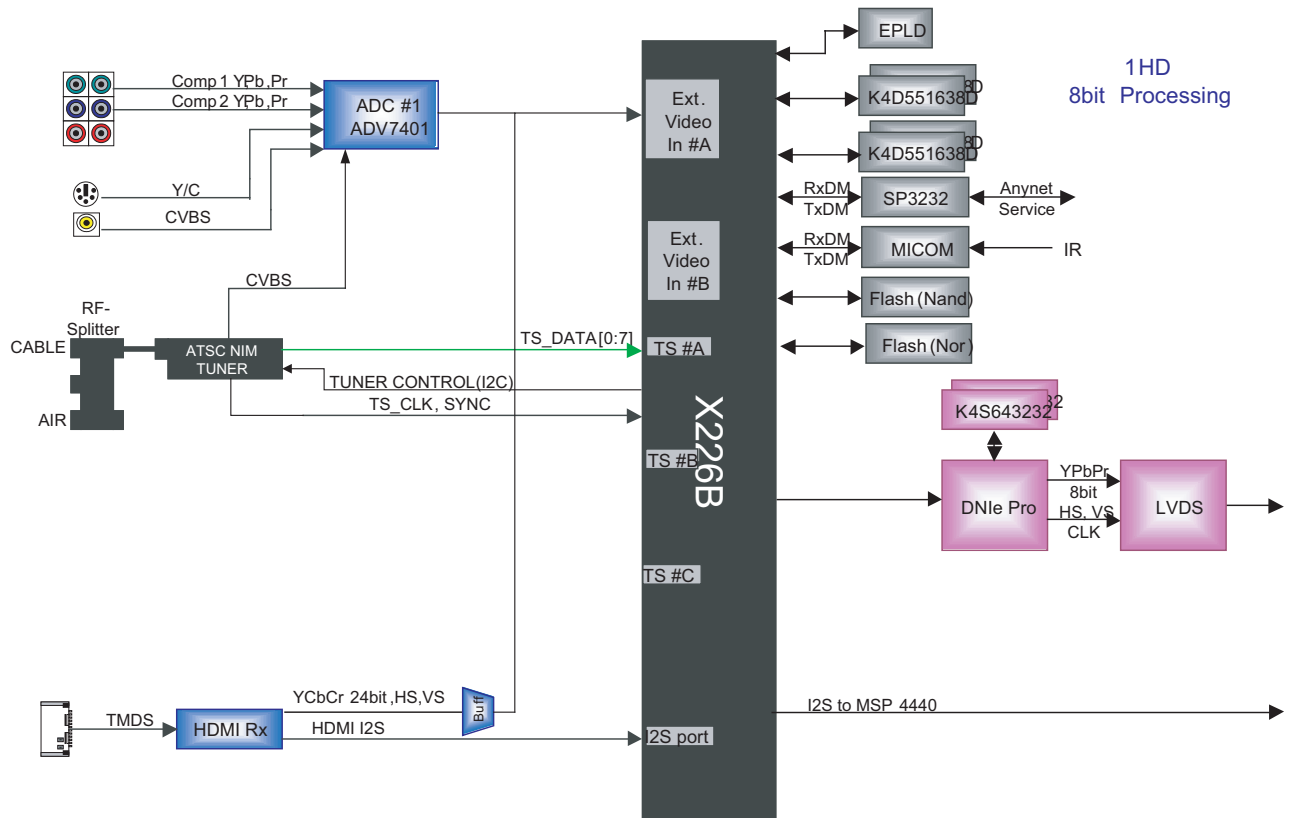

7-2-3 Analog Block Diagram

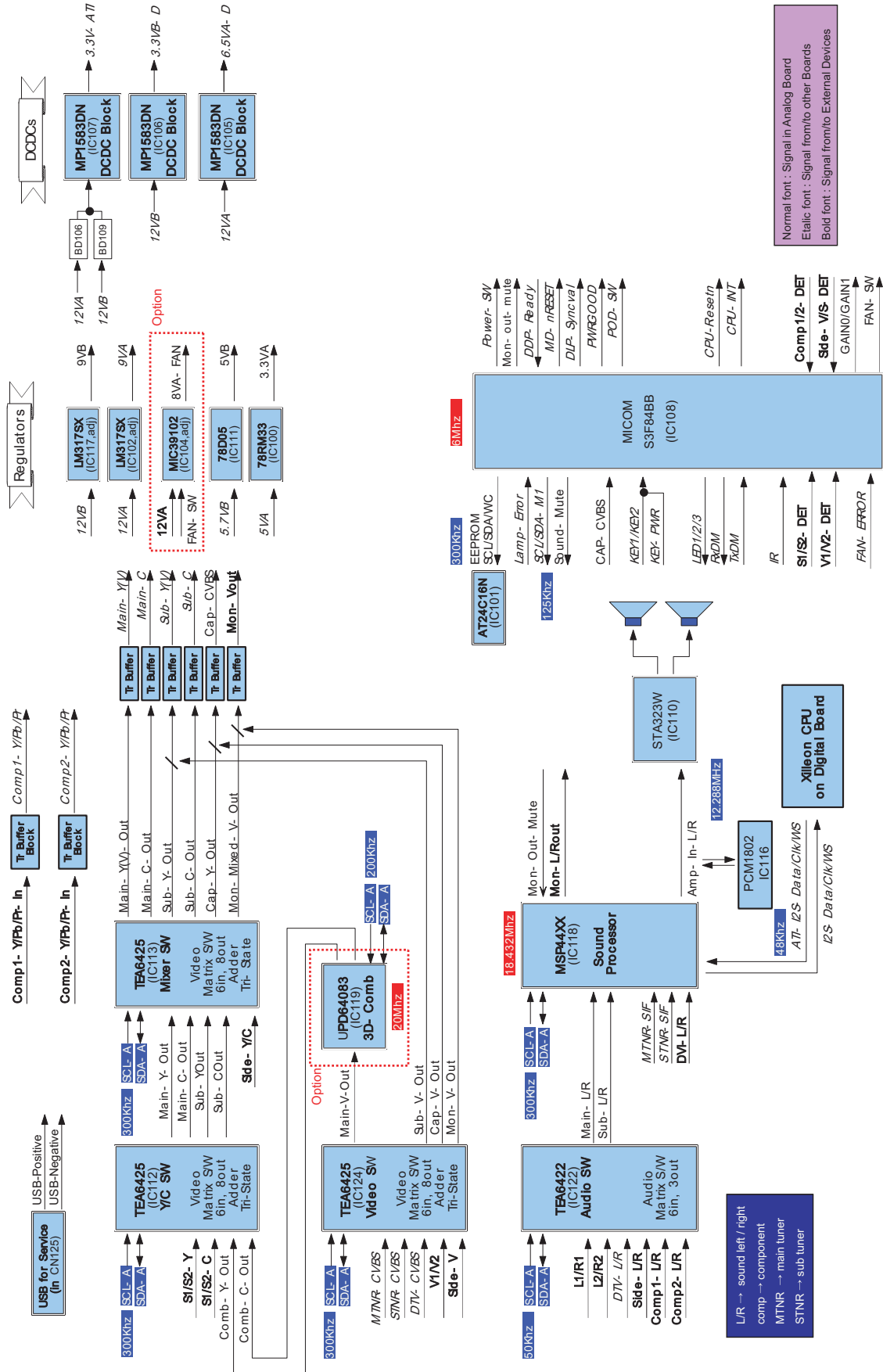

7-2-4 DMD Block Diagram

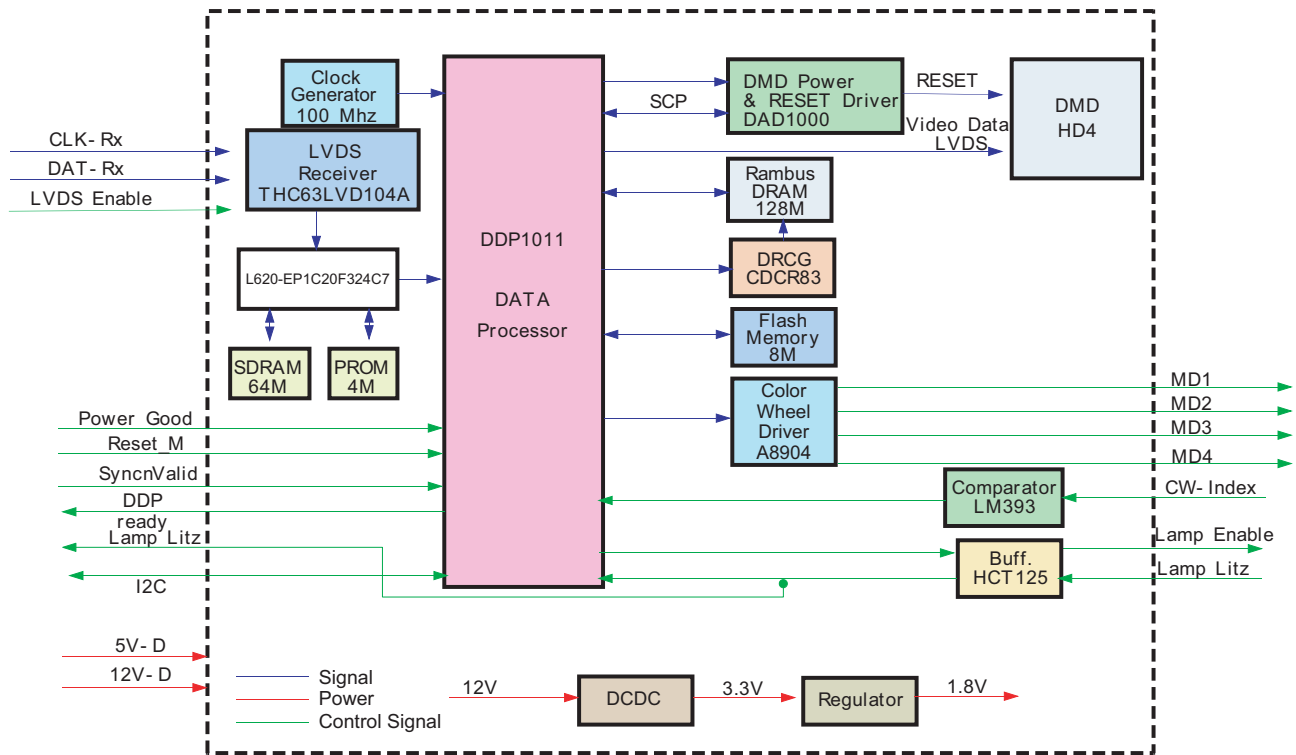

MEMO

9. PCB Diagram

9-1 Power Board

9-1-1 Assy Power Board

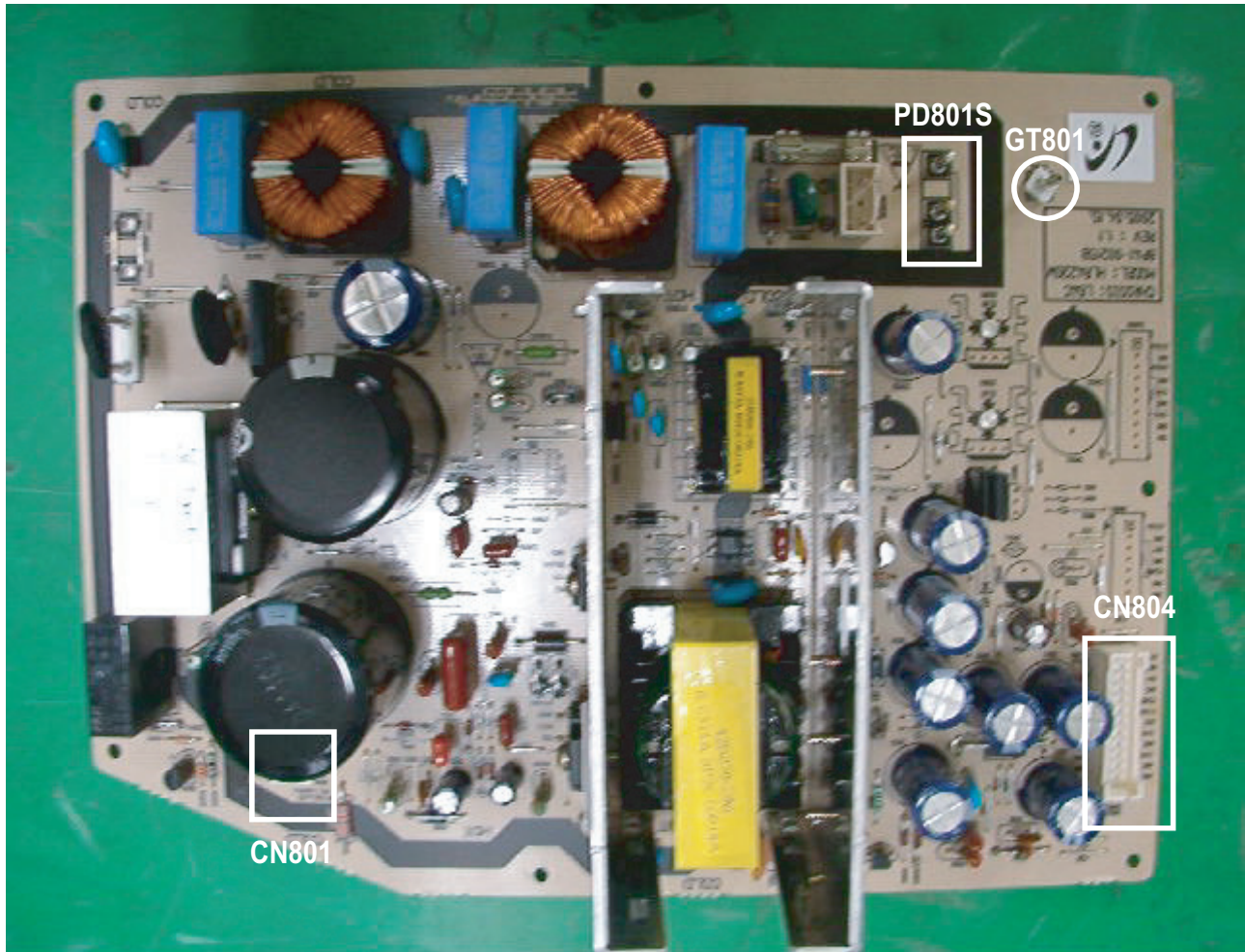

■ DC Power Supply

(Supplies DC power to the analog PCB. The analog board is responsible for the power supply to the digital/DMD board.)

9-1-2 Names & Roles of Key Parts

- * CN801 : Supplies power (DC330V \pm 10%) to the ballast.
- * GT801 : Anti-lightning wire connected to the digital board. The anti-lightning wire should be installed for safety purposes.
- * PD801S : Connecting with power cable.

9-1-3 Power Board Connector Pin

CN804

Connecting Power to Analog Board

Pin Name	PIN No.		Pin Name
STD 5V	1	2	S-MUTE
GND	3	4	S14.5V
33V	5	6	GND
GND	7	8	S14.5V
POWER-SW	9	10	GND
5.5VB	11	12	5.5VB
GND	13	14	GND
12VB	15	16	12VB
GND	17	18	GND
12VB	19	20	12VB
GND	21	22	GND
GND	23	24	80VB

9-2 Digital Board

9-2-1 Assy Digital Board

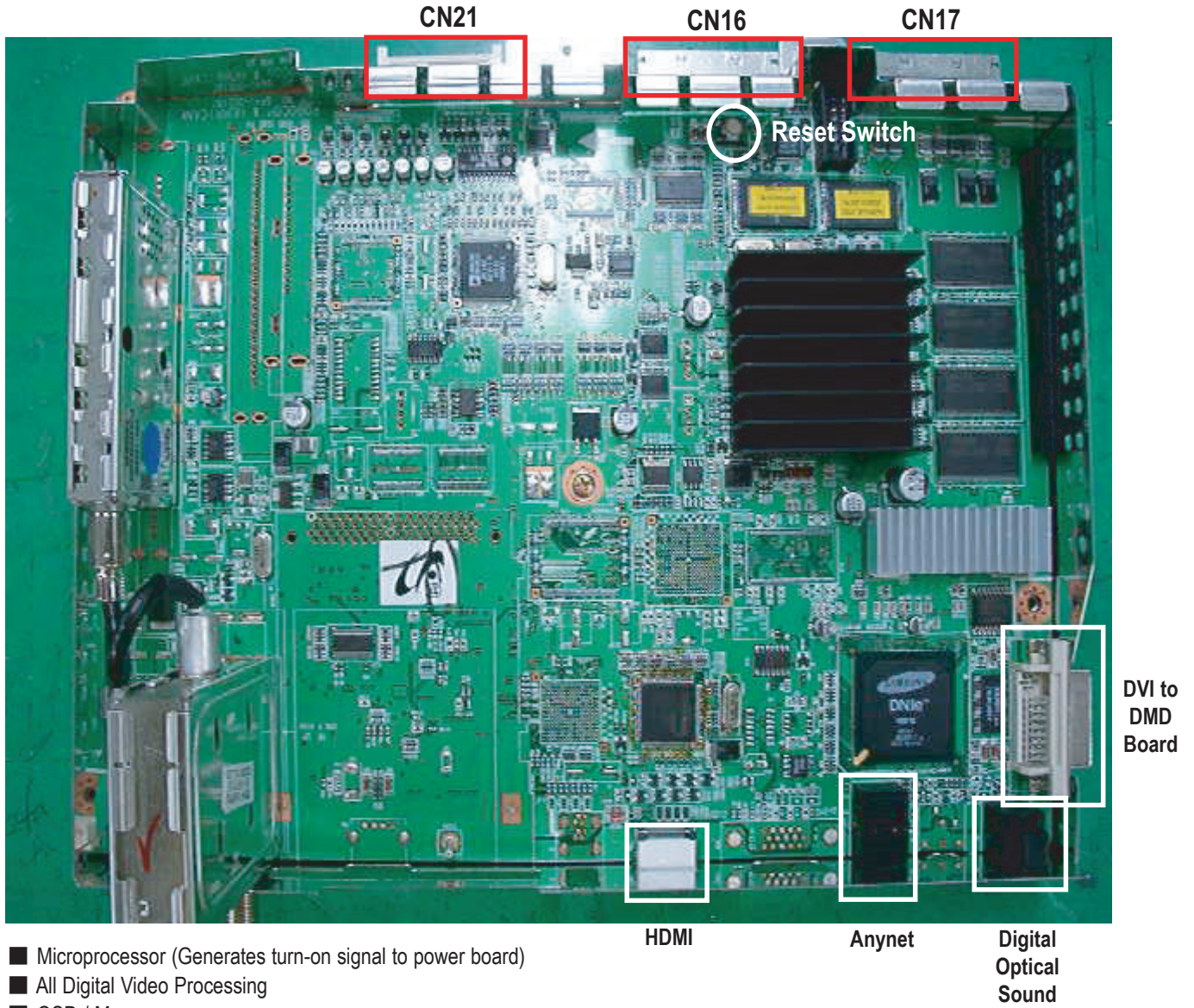

9-2-2 Names & Roles of Key Parts

* High Definition Multimedia Interface :

The HDMI™ (High Definition Multimedia Interface) supports uncompressed standard and high definition digital video formats and existing digital multi-channel audio formats.

* G-Link :

This jack is used by the TV Guide On screen system of the TV to control external analog devices such as VCRs, DVDs, cable boxes, satellite receivers and audio receivers.

* D-Net(IEEE1394) :

These jacks allow the TV to connect to external IEEE 1394 digital products by means of a single cable.

9-2-3 Digital Board Connector Pin

CN16

Connecting the control signal between Digital & Analog Board

Pin Name	PIN No.		Pin Name
I2SWS_OUTA	1	2	TxDM
I2SSD_OUTA	3	4	RxDM
I2SCLK_OUTA	5	6	GND
GND	7	8	SDA_M5
SDA_PANNEL	9	10	SCL_M5
SCL_PANNEL	11	12	NT_I2S_SCLK
GND	13	14	NT_I2S_LRCLK
NT_I2S_DATA	15	16	USB_SW_UP_P
nMICOM_INIT	17	18	USB_SW_UP_N
nRESET	19	20	S_nRESET
ANALOG-nRST	21	22	DDP_READY
MD-nRESET	23	24	PWRGOOD
LAMP-ERROR	25	26	DTV_Lt
DLP-SYNCVAL	27	28	DTV_Rt
GND	29	30	GND

CN17

Connecting Power to the Digital Board

Pin Name	PIN No.		Pin Name
MD3.3V	1	2	MD3.3V
MD3.3V	3	4	D3.3V
GND	5	6	D3.3V
GND	7	8	GND
STB_6.5V	9	10	GND
GND	11	12	GND
STB_9V	13	14	D5.7V
GND	15	16	D5.7V
STB_30V	17	18	GND
STB_5V	19	20	GND
5VA	21	22	D12V
GND	23	24	GND
GND	25	26	D9V
33V	27	28	GND

CN21

Connecting the Audio/Video signal from the rear input terminal

Pin Name	PIN No.		Pin Name
MAIN_Y	1	2	GND
MAIN_C	3	4	GND
SUB_Y	5	6	GND
SUB_C	7	8	GND
DTV_CVBS	9	10	GND
COMP1_Y	11	12	GND
COMP1_Pb	13	14	GND
COMP1_Pr	15	16	GND
COMP2_Y	17	18	GND
COMP2_Pb	19	20	GND
COMP2_Pr	21	22	GND
M-CVBS	23	24	GND
M-SIF	25	26	GND
S-CVBS	27	28	GND
S-SIF	29	30	GND

9-3 Analog Board

9-3-1 Assy Analog Board

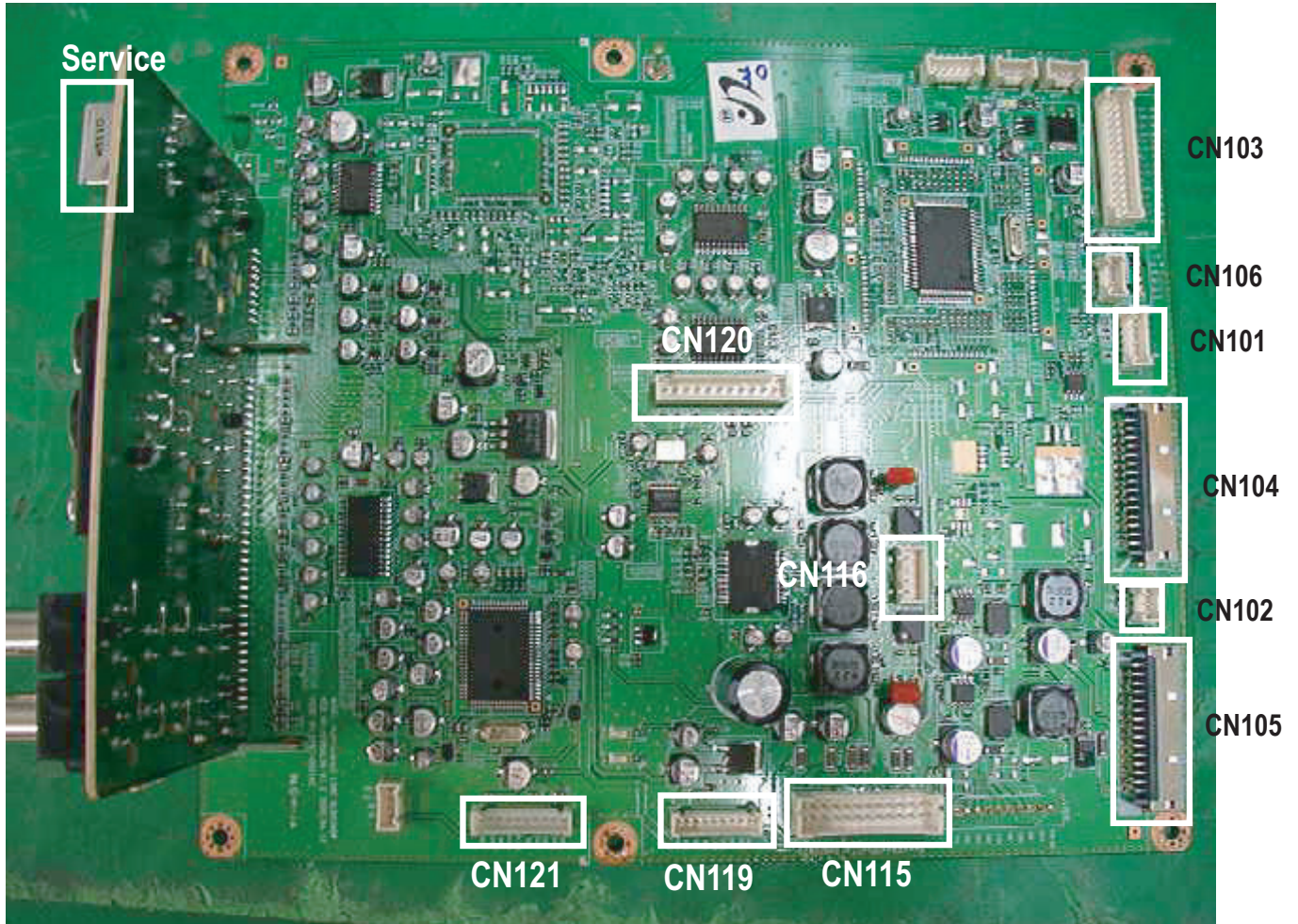

- Distributes supply voltage from the Power Board to Digital Board and DMD Board.
- Transfers Turn-on Command to Digital and Power Board.
- Encompasses the majority of the Audio Circuit
- Analog Video Switching / Processing
- Analog Audio Switching / Processing

9-3-2 Names & Roles of Key Parts

- * CN121 : Connected to the actuator board
- * CN119 : Connected to the DMD board
- * CN115 : Connected to the power board - receives the second power source generated on the power board.
- * CN105 : Sends the power source from the analog to the digital board.
- * CN104 : This is a control signal terminal that connects between the analog and digital boards.
- * CN103 : This is an AV signal terminal that connects between the analog and digital boards.

9-3-3 Analog Board Connector Pin

CN119

Connecting Power to the DMD

Pin No.	Pin Name
1	5VB
2	5VB
3	GND
4	GND
5	12VB
6	12VB
7	GND
8	GND
9	GND

CN106

Connecting Side Buttons

Pin No.	Pin Name
1	GND
2	KEY1
3	KEY2
4	GND

CN105

Connecting Power to the Digital Board

Pin Name	PIN No.		Pin Name
3.3V-ATI	1	2	3.3V-ATI
3.3VB-D	3	4	3.3V-ATI
3.3VB-D	5	6	GND
GND	7	8	GND
GND	9	10	6.5VA-D
GND	11	12	GND
5.7VB	13	14	9VA
5.7VB	15	16	GND
GND	17	18	30VA
GND	19	20	5VA
12VB	21	22	5VA
GND	23	24	GND
9VB	25	26	GND
GND	27	28	33VB
GND	29	30	GND

CN123

For Debugging

Pin No.	Pin Name
1	SDA-A
2	SCL-A
3	GND
4	5VA

CN121

Connecting Power and the Control Signal to the Actuator Protection Board

Pin No.	Pin Name
1	GND
2	12VB
3	GND
4	SDA-M1
5	SCL-M1
6	GND
7	5VA
8	GND
9	70VB
10	GND

CN102

Connecting the IR signal

Pin No.	Pin Name
1	IR
2	GND
3	5VA

CN101

Connecting front LED indicators

Pin No.	Pin Name
1	5VA
2	KEY-PWR
3	GND
4	LED1
5	LED2
6	LED3

CN116

Connecting and transmitting Audio signal to Speaker

Pin No.	Pin Name
1	-L-OUT
2	+L-OUT
3	-R-OUT
4	+R-OUT

CN105

Connecting Power

Pin Name	PIN No.		Pin Name
5VA	1	2	POWER-MUTE
GND	3	4	S16VB
33VB	5	6	GND
GND	7	8	S16VB
POWER-SW	9	10	GND
5.7VB	11	12	5.7VB
GND	13	14	GND
12VB	15	16	12VB
GND	17	18	GND
12VB	19	20	12VB
GND	21	22	GND
GND	23	24	70VB

CN103

Connecting the Audio/Video signal from the rear input terminal

Pin Name	PIN No.		Pin Name
MAIN_Y	1	2	GND
MAIN_C	3	4	GND
SUB_Y_V	5	6	GND
SUB_C	7	8	GND
DTV_CVBS	9	10	GND
COMP1_Y	11	12	GND
COMP1_Pb	13	14	GND
COMP1_Pr	15	16	GND
COMP2_Y	17	18	GND
COMP2_Pb	19	20	GND
COMP2_Pr	21	22	GND
MTNR_CVBS	23	24	GND
MTNR_SIF	25	26	GND
STNR_CVBS	27	28	GND
STNR_SIF	29	30	GND

CN120

Transmitting Video Signal from Side Terminal

Pin No.	Pin Name
1	SIDE-Y
2	SIDE-C
3	GND
4	SIDE-V
5	GND
6	SIDE-L
7	GND
8	SIDE-R
9	GND
10	SIDE-SDET
11	SIDE-VDET

CN104

Connecting the control signal between Digital and Analog

Pin Name	PIN No.		Pin Name
TxDM	1	2	ATI-I2S-WS
RxDM	3	4	ATI-I2S-DATA
GND	5	6	STI-I2S-CLK
SDA_A	7	8	GND
SCL_A	9	10	SDA_DMD
I2SCLK	11	12	SCL_DMD
I2S_WS	13	14	GND
USB_POS	15	16	I2S_DATA
USB_NEG	17	18	CPU_INIT
SOUND_RESET	19	20	CPU_RESET
DDP_READY	21	22	RESET_D
PWRGOOD	23	24	MD_nRESET
DTV_L	25	26	LAMP_ERROR
DTV_R	27	28	DLP_SYNCVAL
GND	29	30	GND

9-4 DMD Board

9-4-1 Assy DMD Board

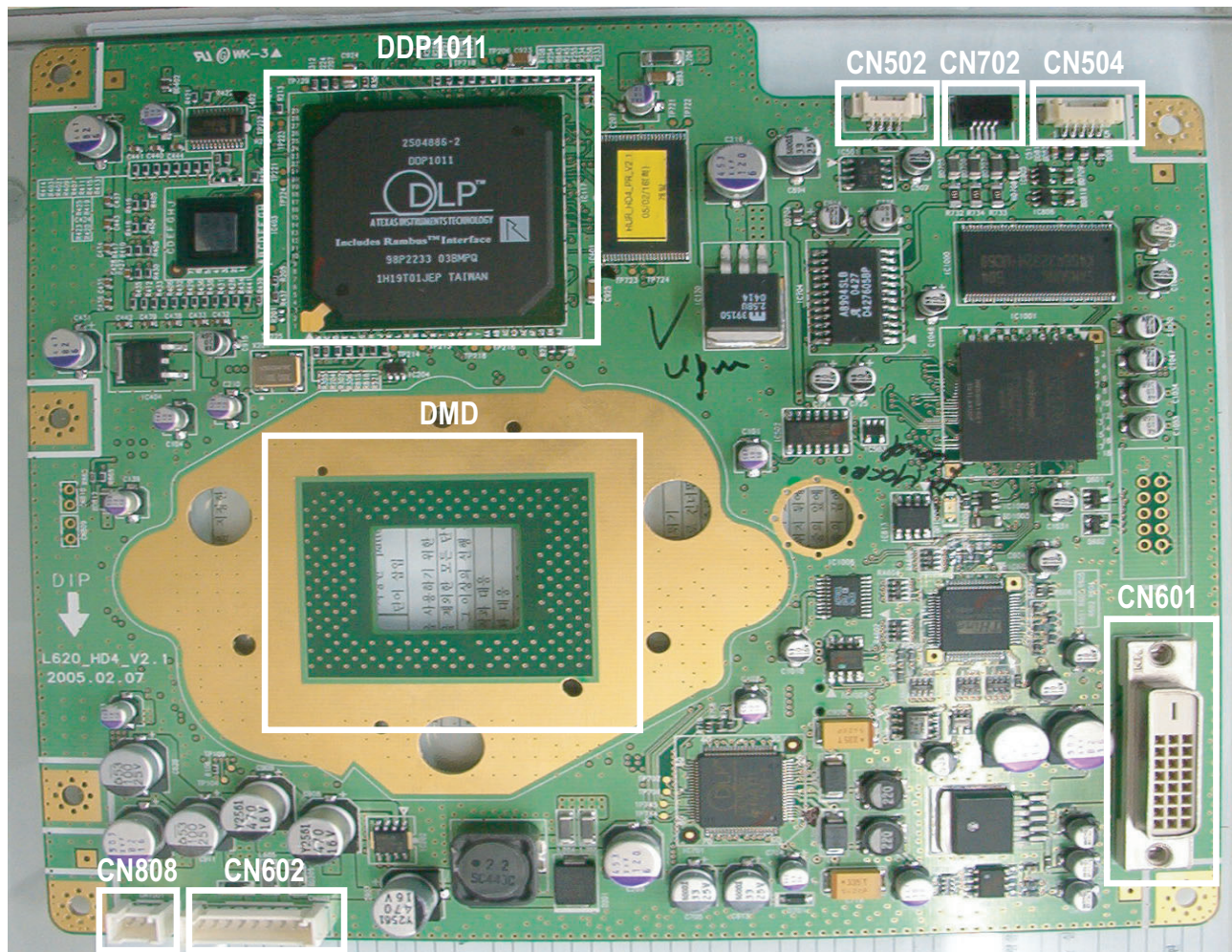

- Controls the lamp (ON/OFF)
- Drives the color wheel motor
- Drives the panel
- Controls the sensors

9-4-2 Names & Roles of Key Parts

- * CN602 : This receives the power source from the analog board and communicates with the I2C.
- * CN808 : This sends a 60Hz signal to the actuator board. The actuator board sends the signal to the actuator module.
- * CN702 : This supplies the power to drive the color wheel.
- * CN502 : This receives the color wheel rotating signals.
- * CN504 : This sends signals to the ballast.
- * CN601 : The DVD cable terminal. This receives the image data from the digital board.
- * DMD PANEL : This is protected with a heat sink and fixtures.
- * DDP1011 : This processes the DMD drive and the signals.

MEMO

10-1-2 DCDC

This Document can not be used without Samsung's authorization.

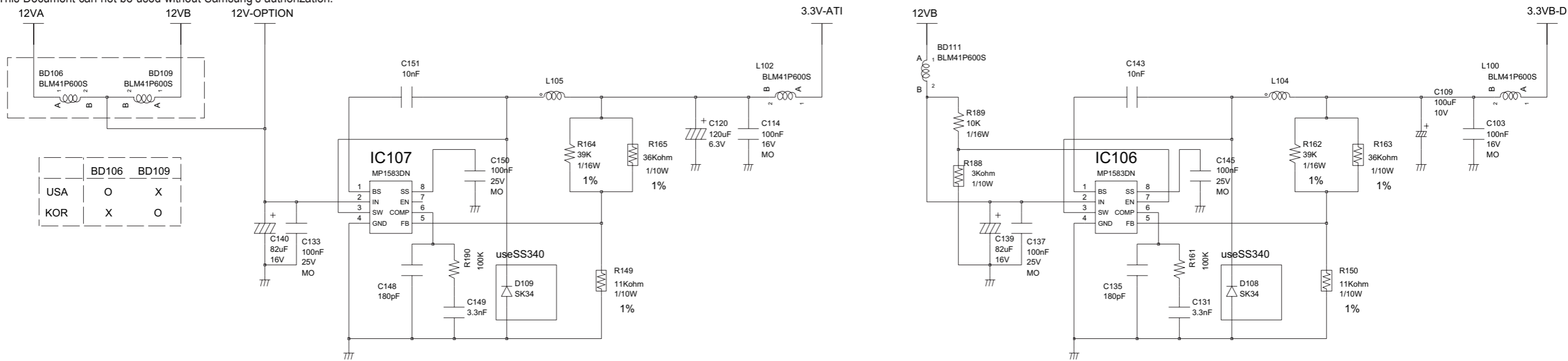

	BD106	BD109
USA	O	X
KOR	X	O

DCDC Converter for Power of ATI-CPU

USA : STD power
KOR : B+ power

DCDC Converter for Power of ATI-CPU

USA/KOR Common B+ power

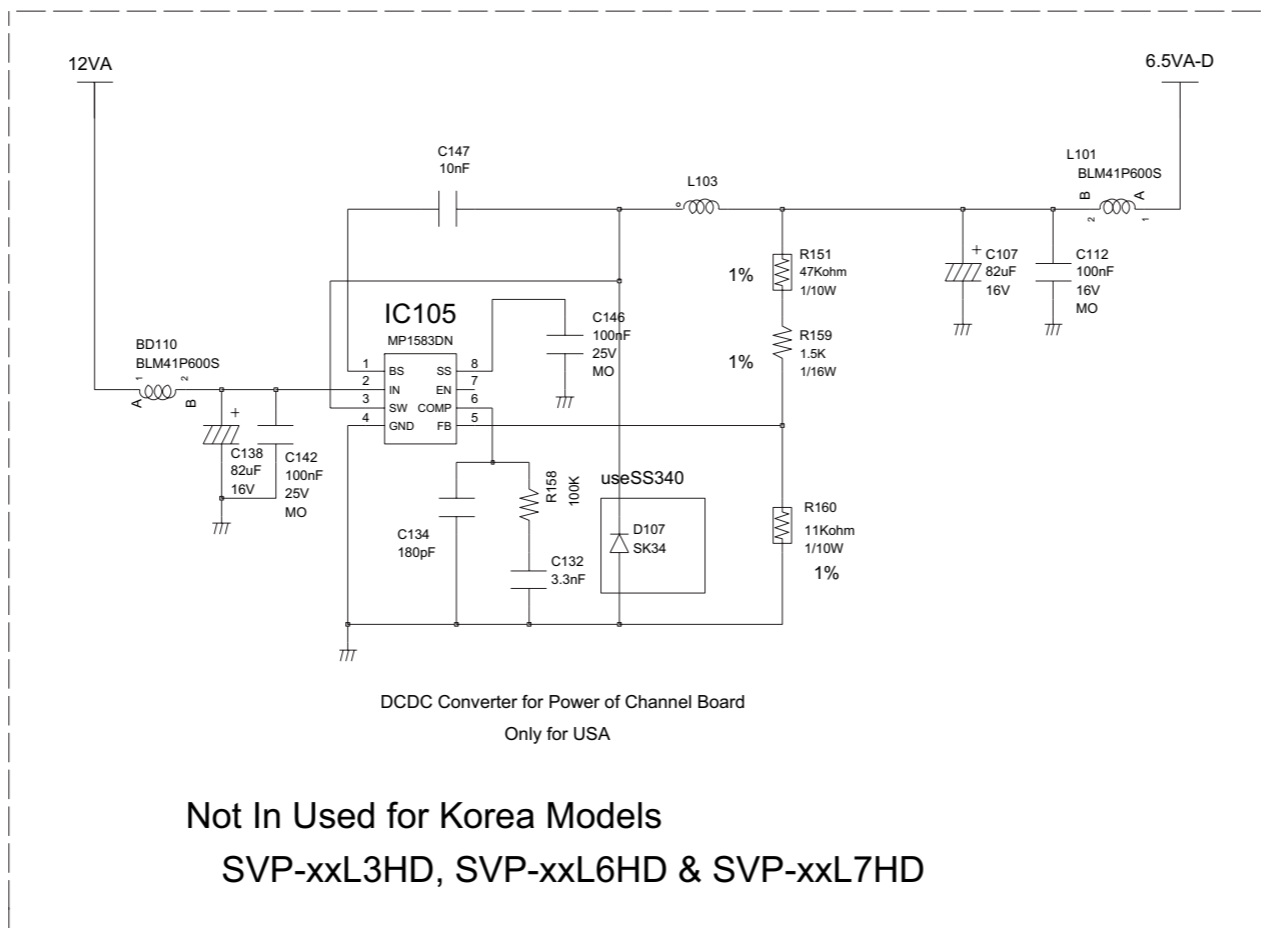

DCDC Converter for Power of Channel Board

Only for USA

Not In Used for Korea Models

SVP-xxL3HD, SVP-xxL6HD & SVP-xxL7HD

10-1-3 AV_Input

This Document can not be used without Samsung's authorization.

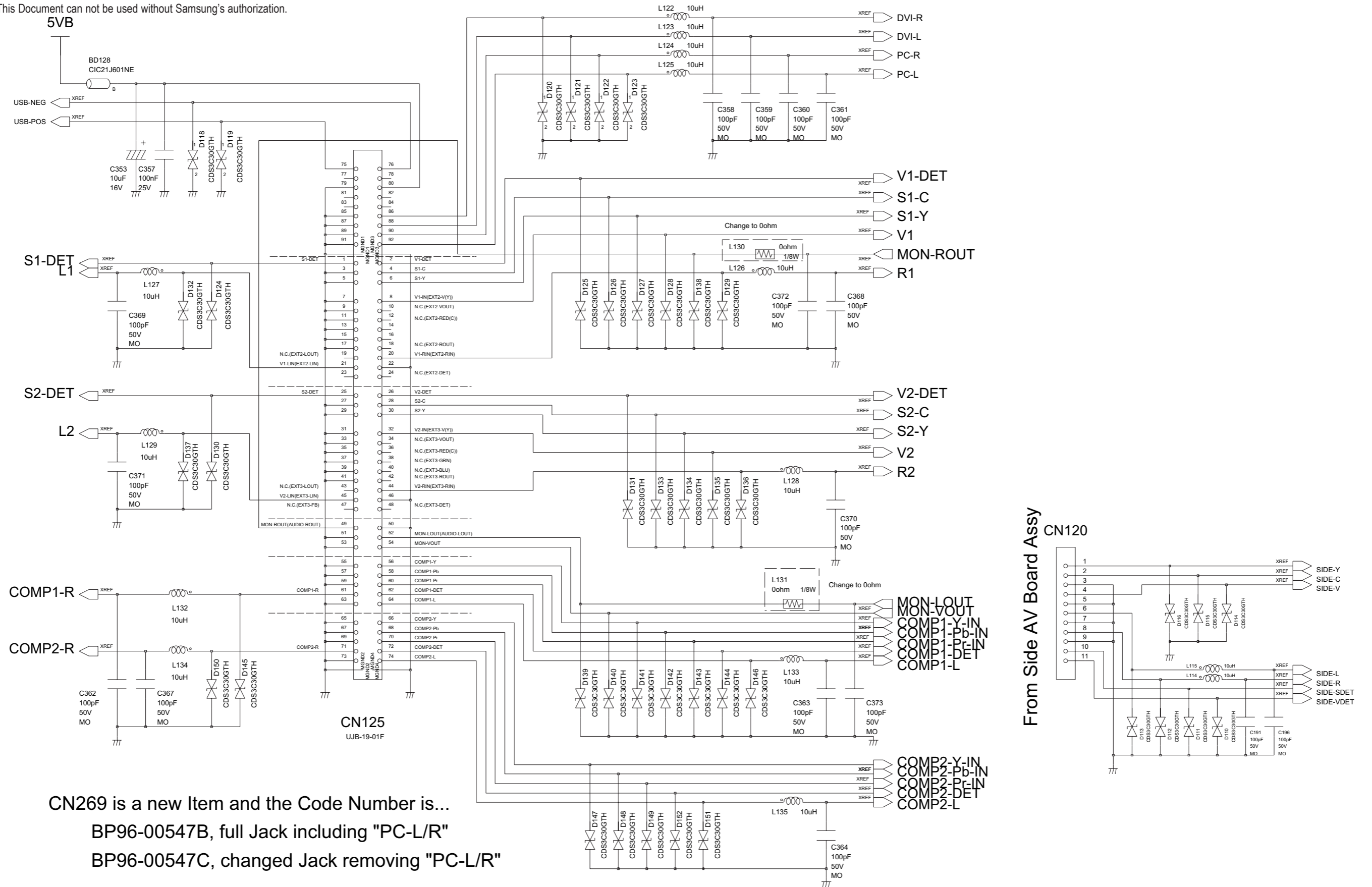

CN269 is a new Item and the Code Number is...
 BP96-00547B, full Jack including "PC-L/R"
 BP96-00547C, changed Jack removing "PC-L/R"

10-1-4 A/V Switching

This Document can not be used without Samsung's authorization.

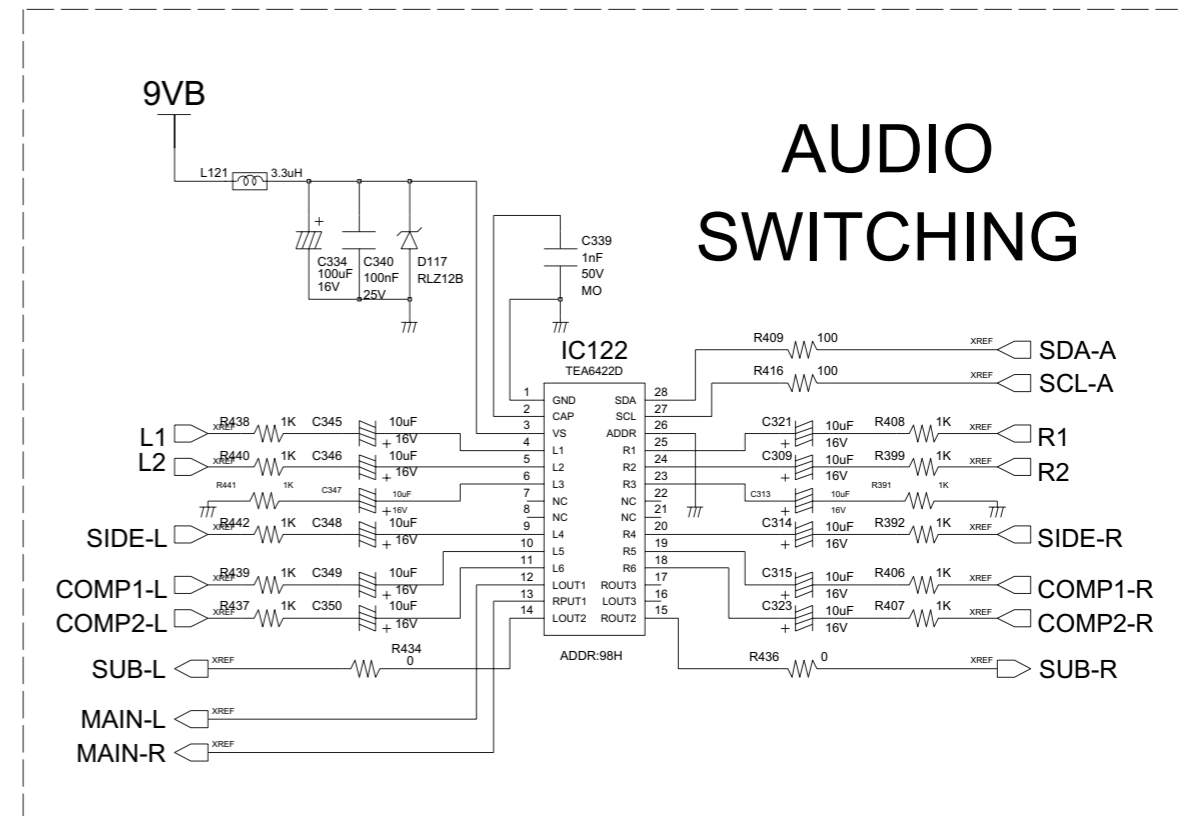
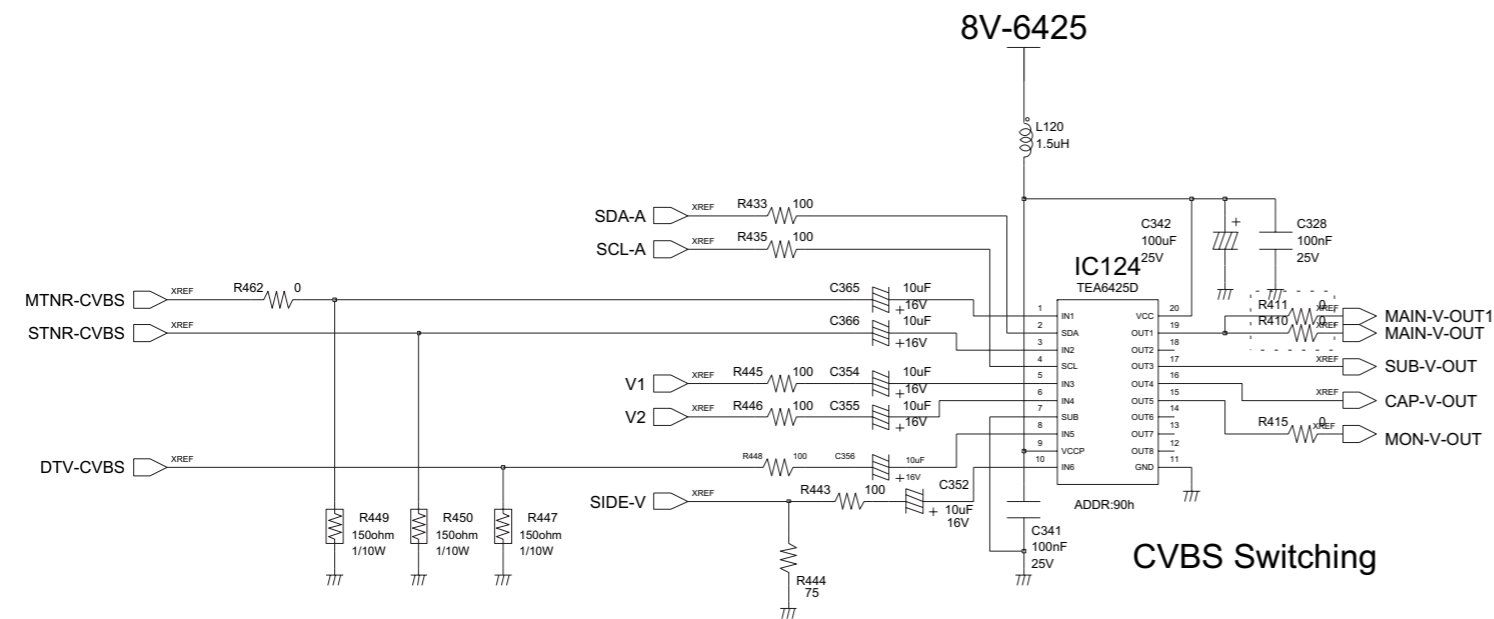
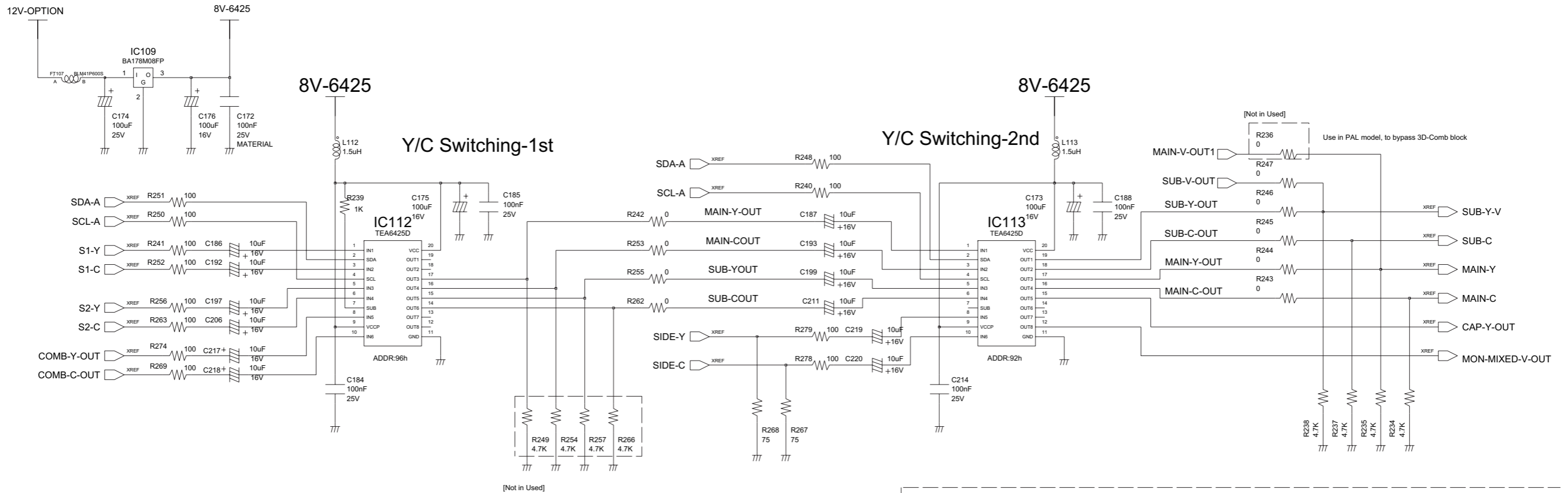

10-1-5 AV_Comp_Buffer

This Document can not be used without Samsung's authorization.

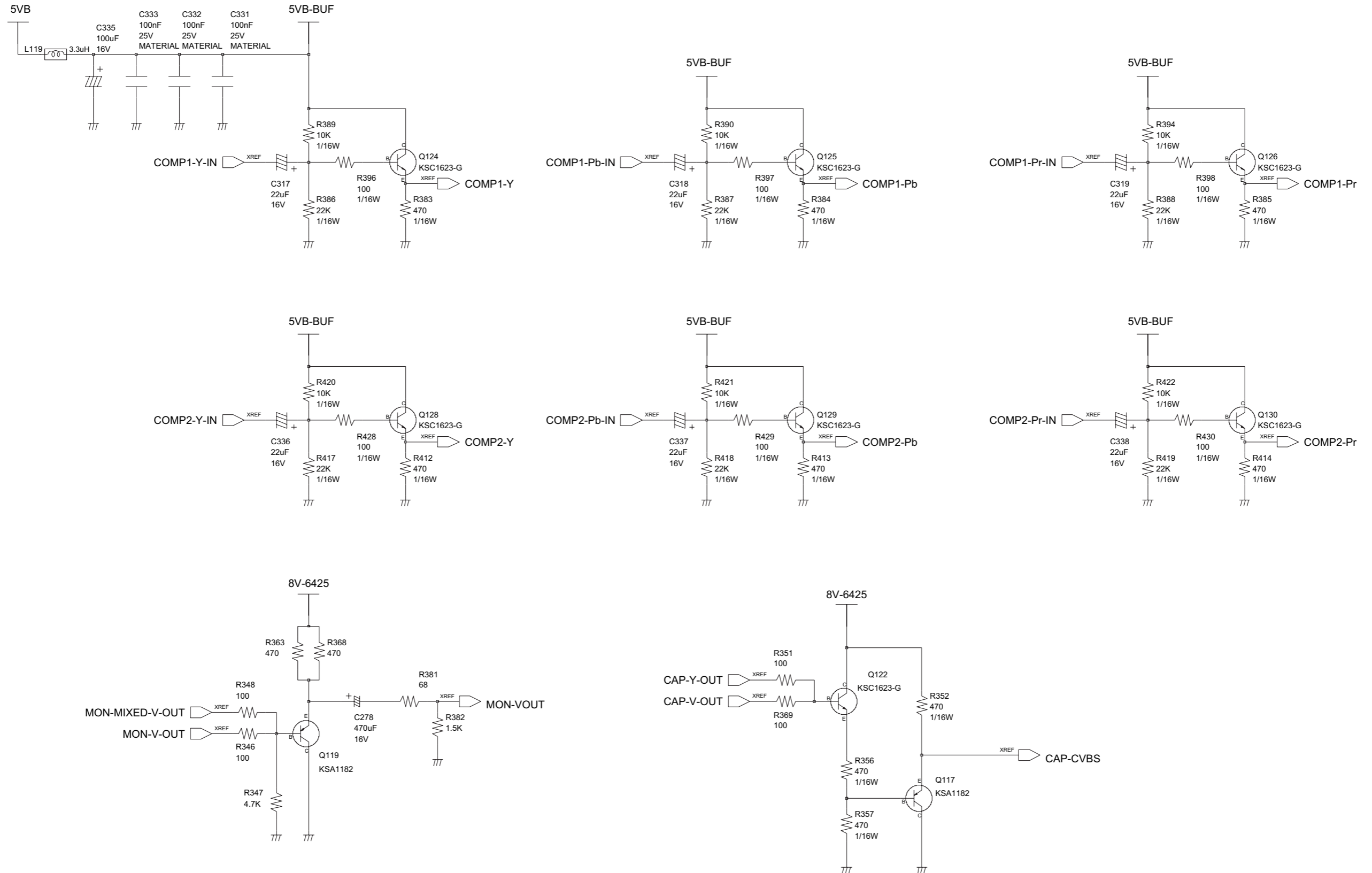

10-1-6 3D-Comb

This Document can not be used without Samsung's authorization.

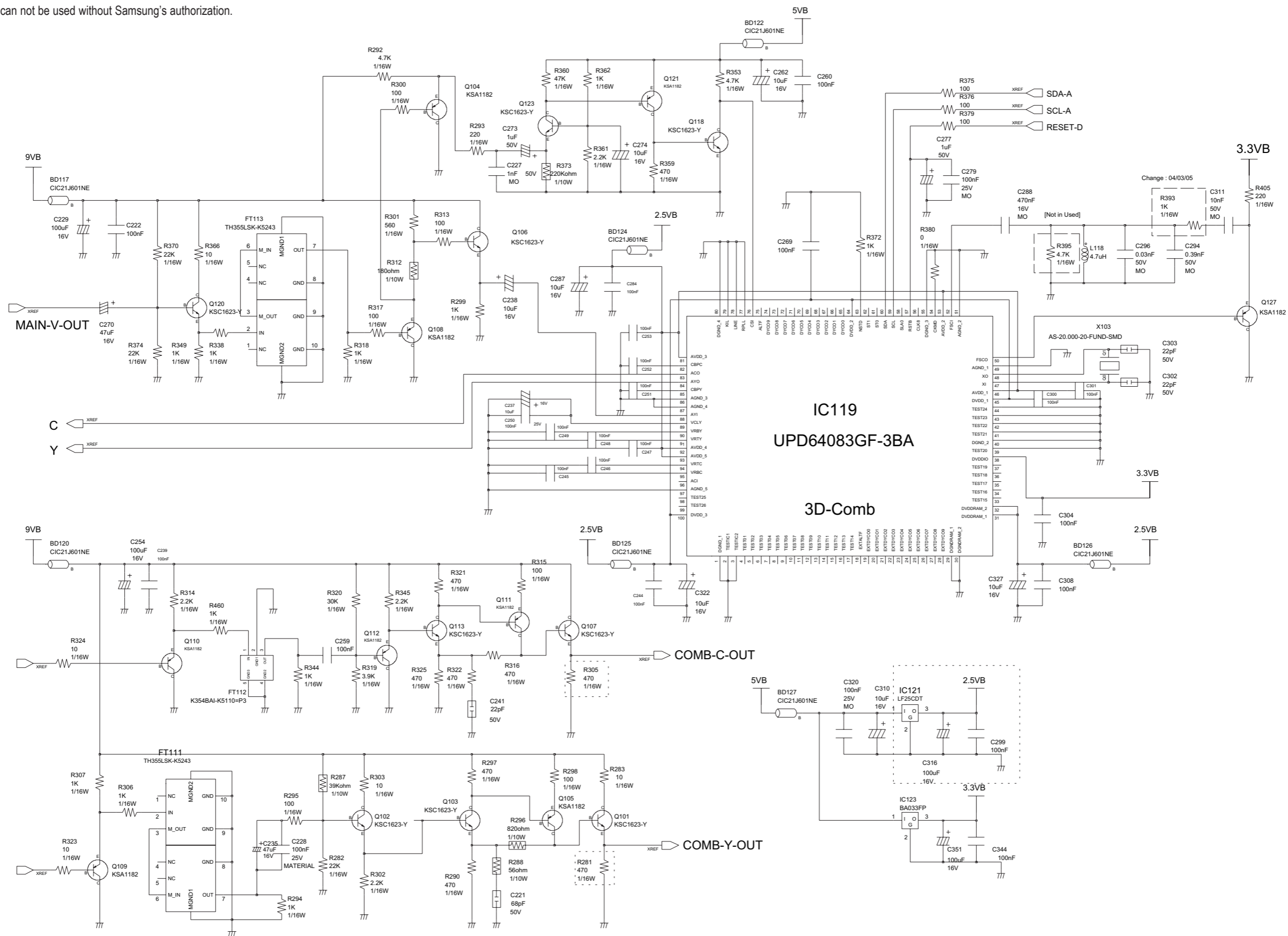

10-1-7 Sound Processor/Amp

This Document can not be used without Samsung's authorization.

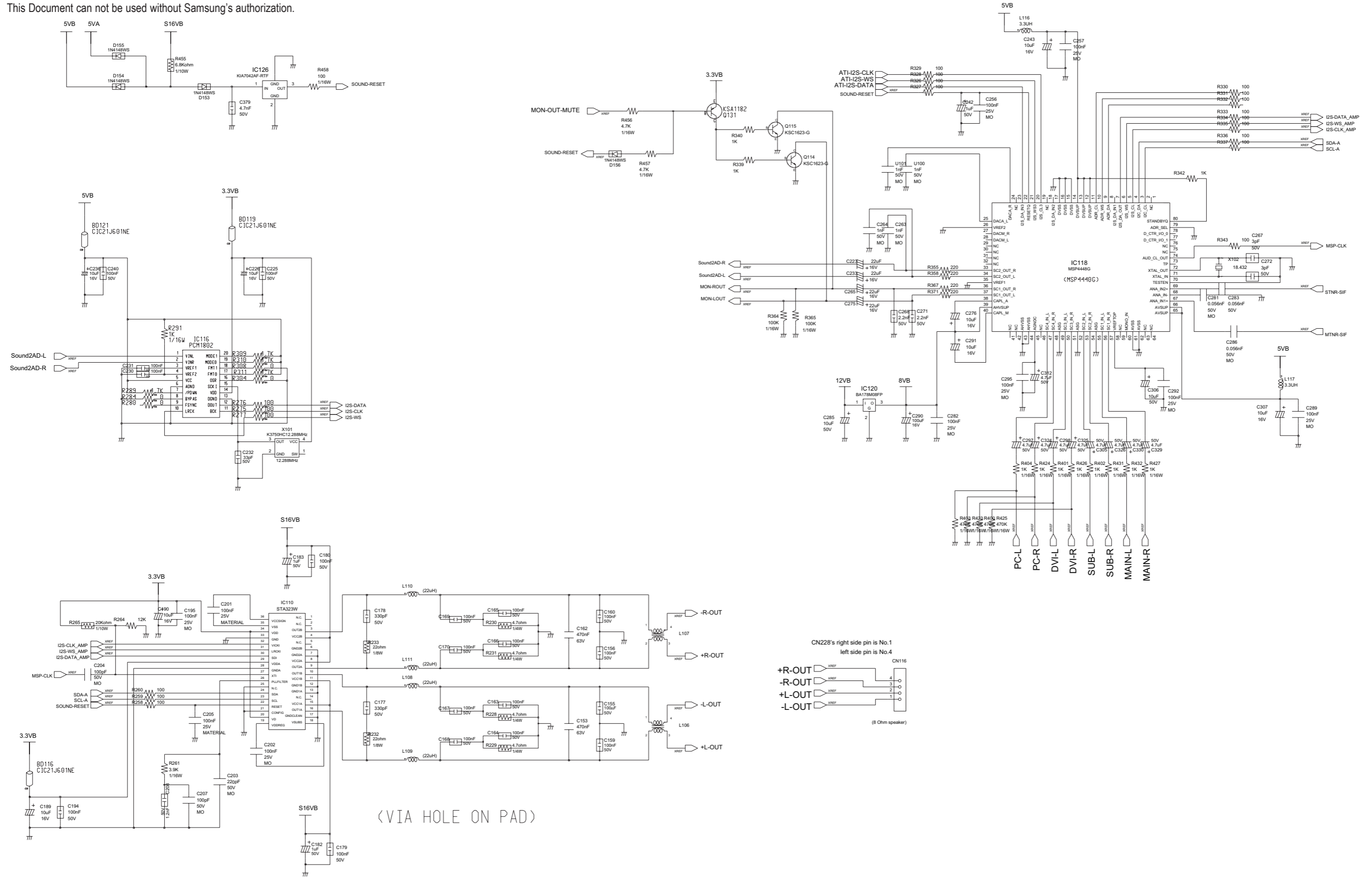

10-1-9 Signal Connection

This Document can not be used without Samsung's authorization.

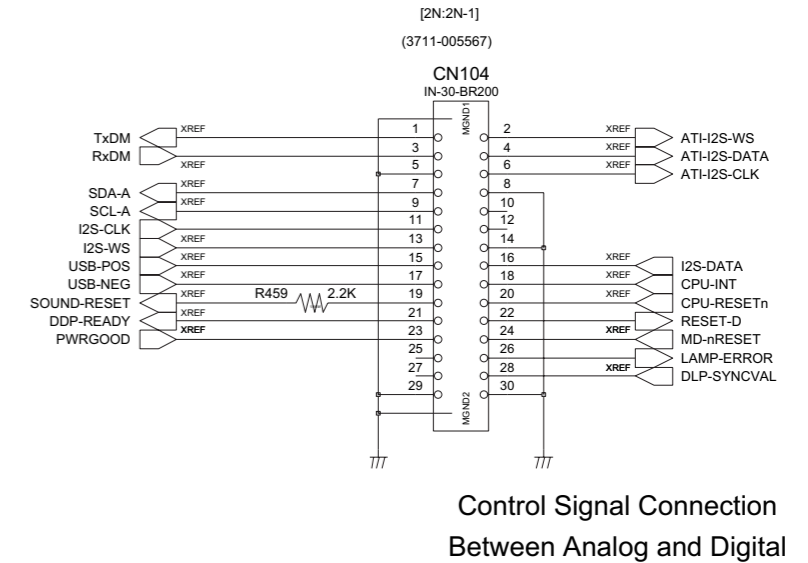
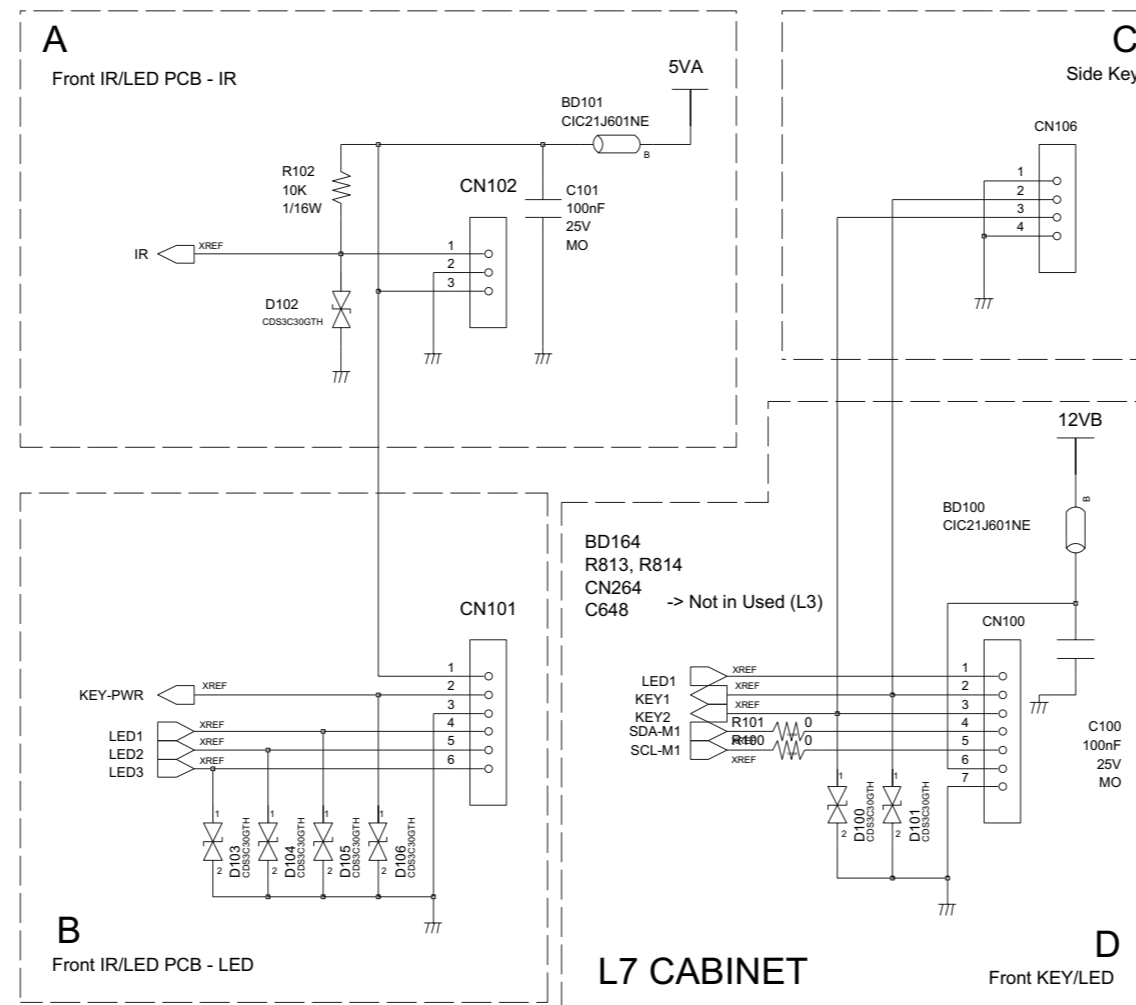
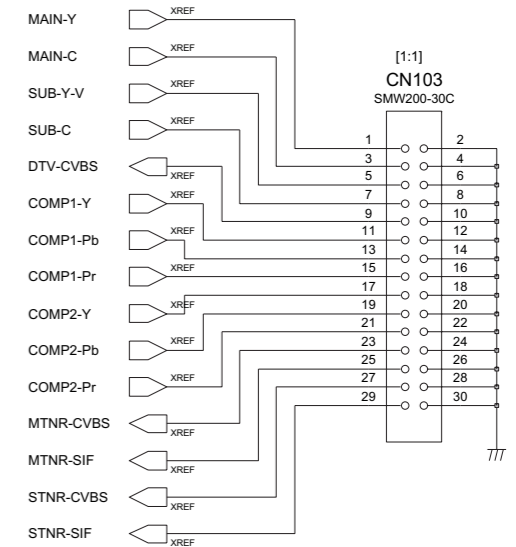
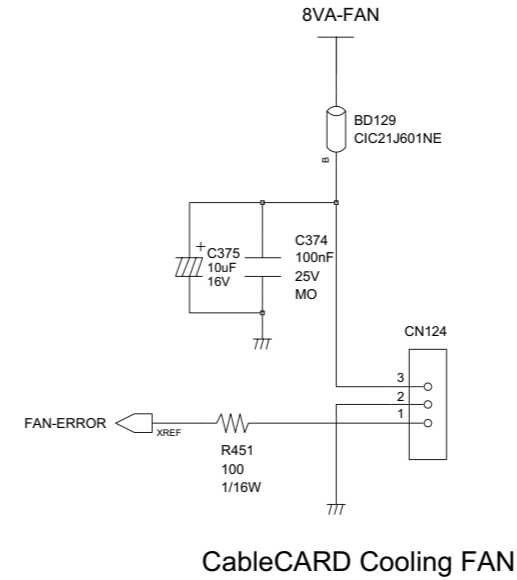
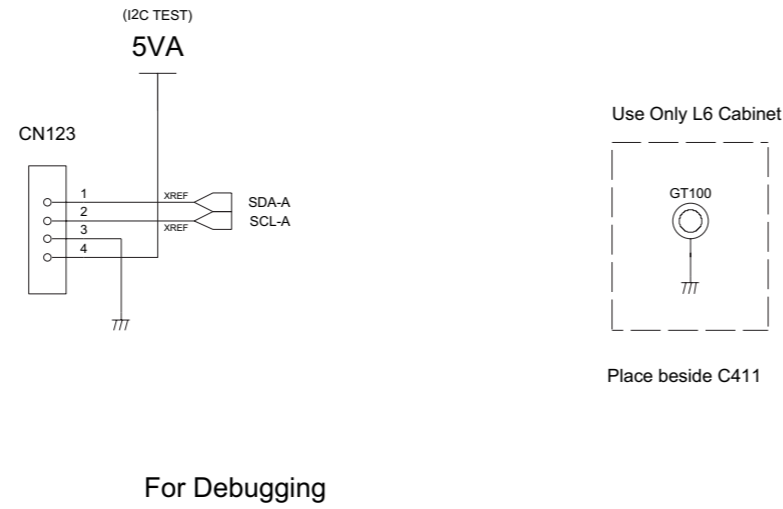
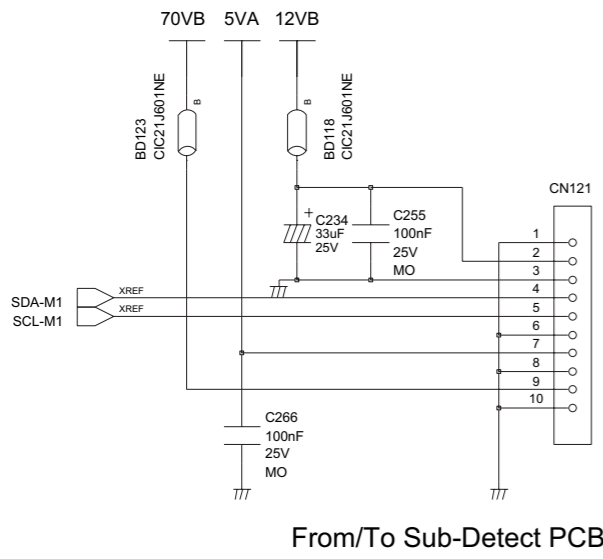

A	B	C	D
1. IR	1. 5VA	1. GND	1. LED1
2. GND	2. KEY-PWR	2. KEY1	2. KEY1
3. 5VA	3. GND	3. KEY2	3. KEY2
	4. LED1	4. GND	4. SDA-M1
	5. LED2		5. SCL-M1
	6. LED3		6. 5VB
			7. GND

Used as follows...
L3 : A+B, C
L5 : A, B, C
L7 : A, D

10-2-2 DTV Module-2

This Document can not be used without Samsung's authorization.

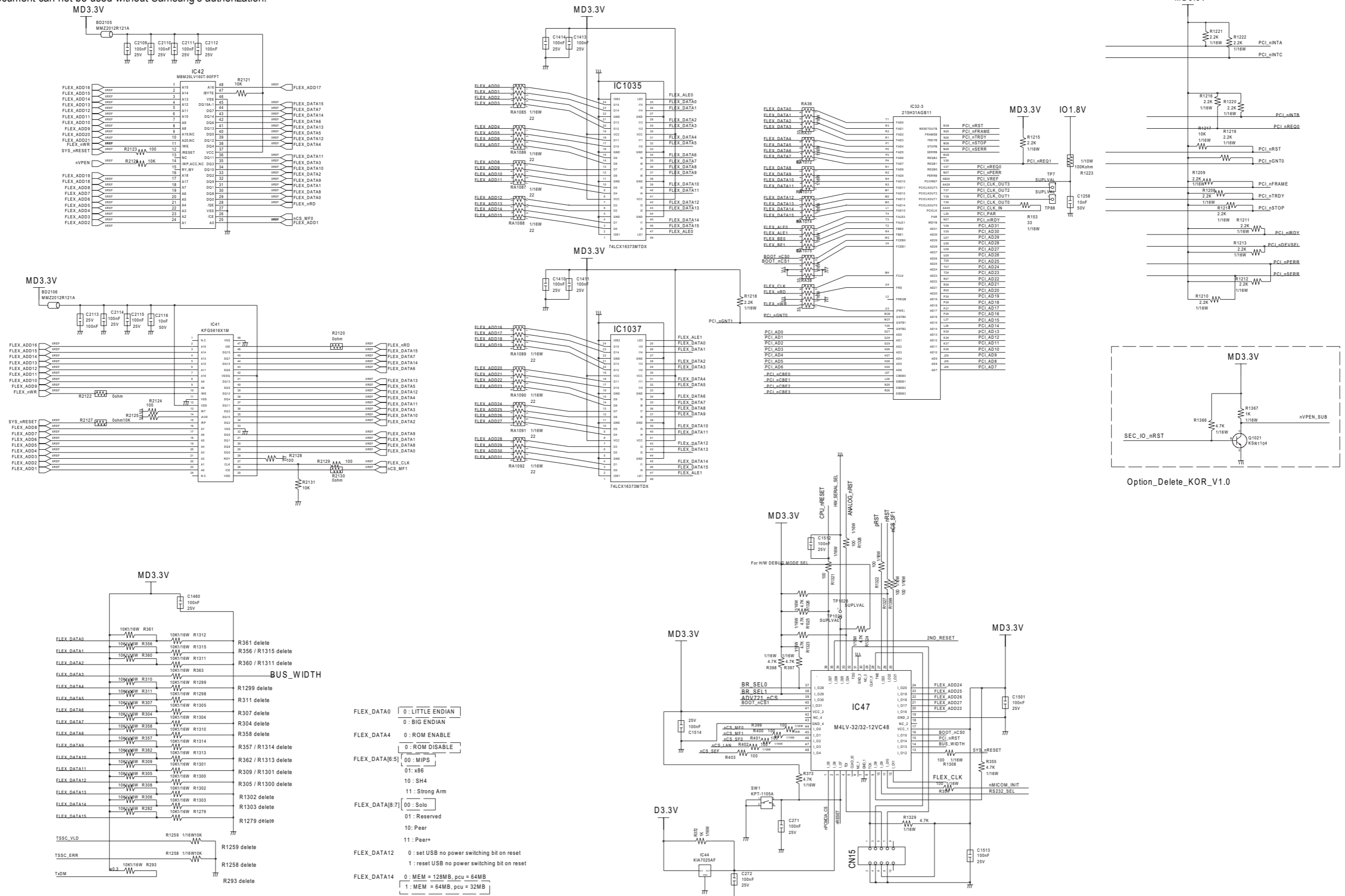

10-2-3 DTV Module-3

This Document can not be used without Samsung's authorization.

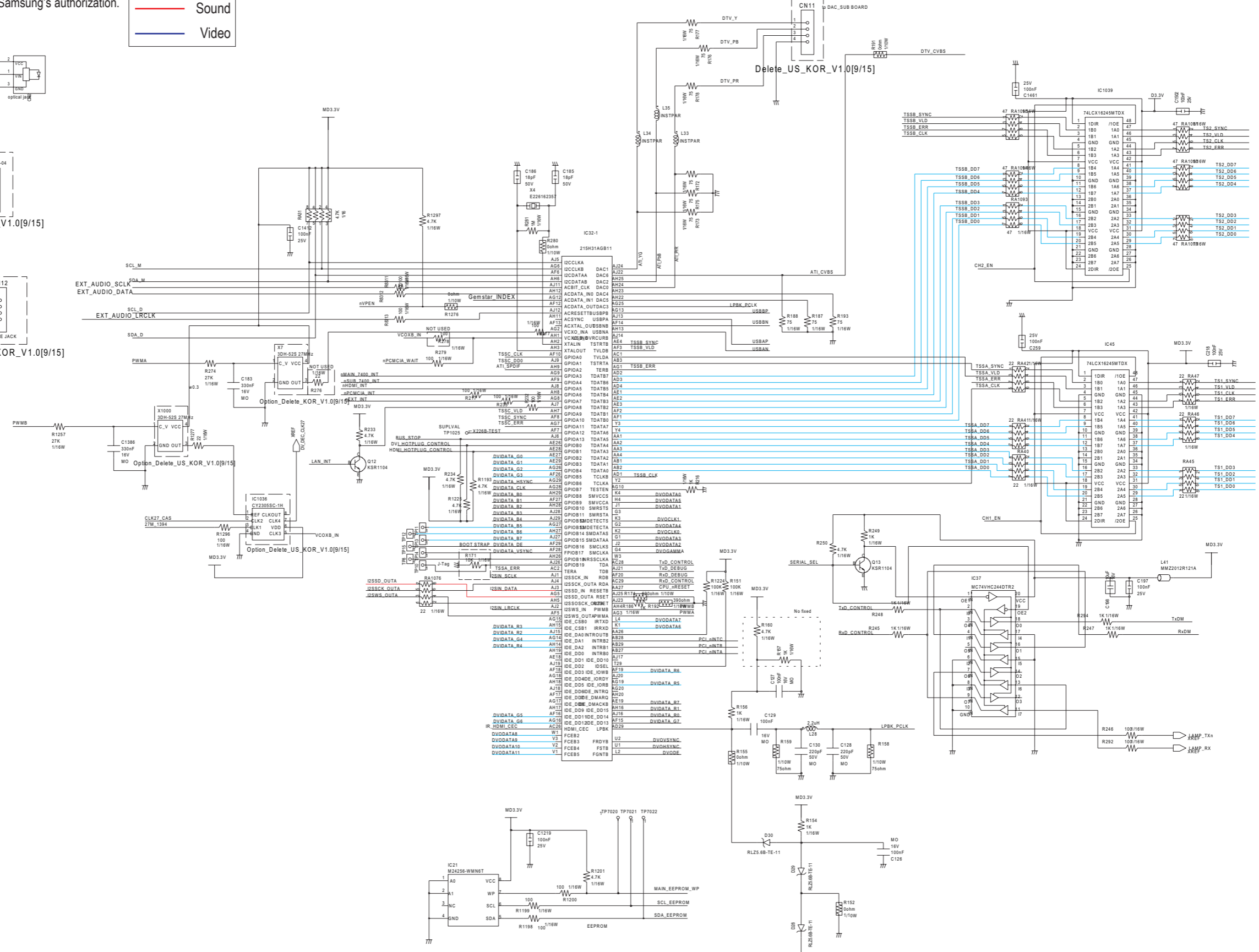
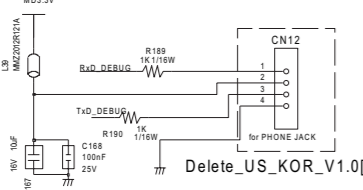
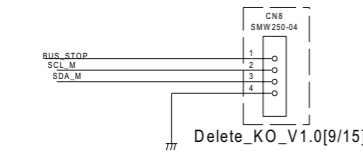
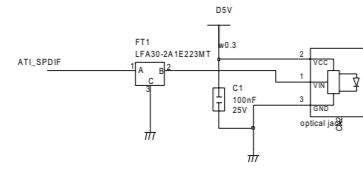

10-2-6 DTV Module-6

This Document can not be used without Samsung's authorization.

Option default add

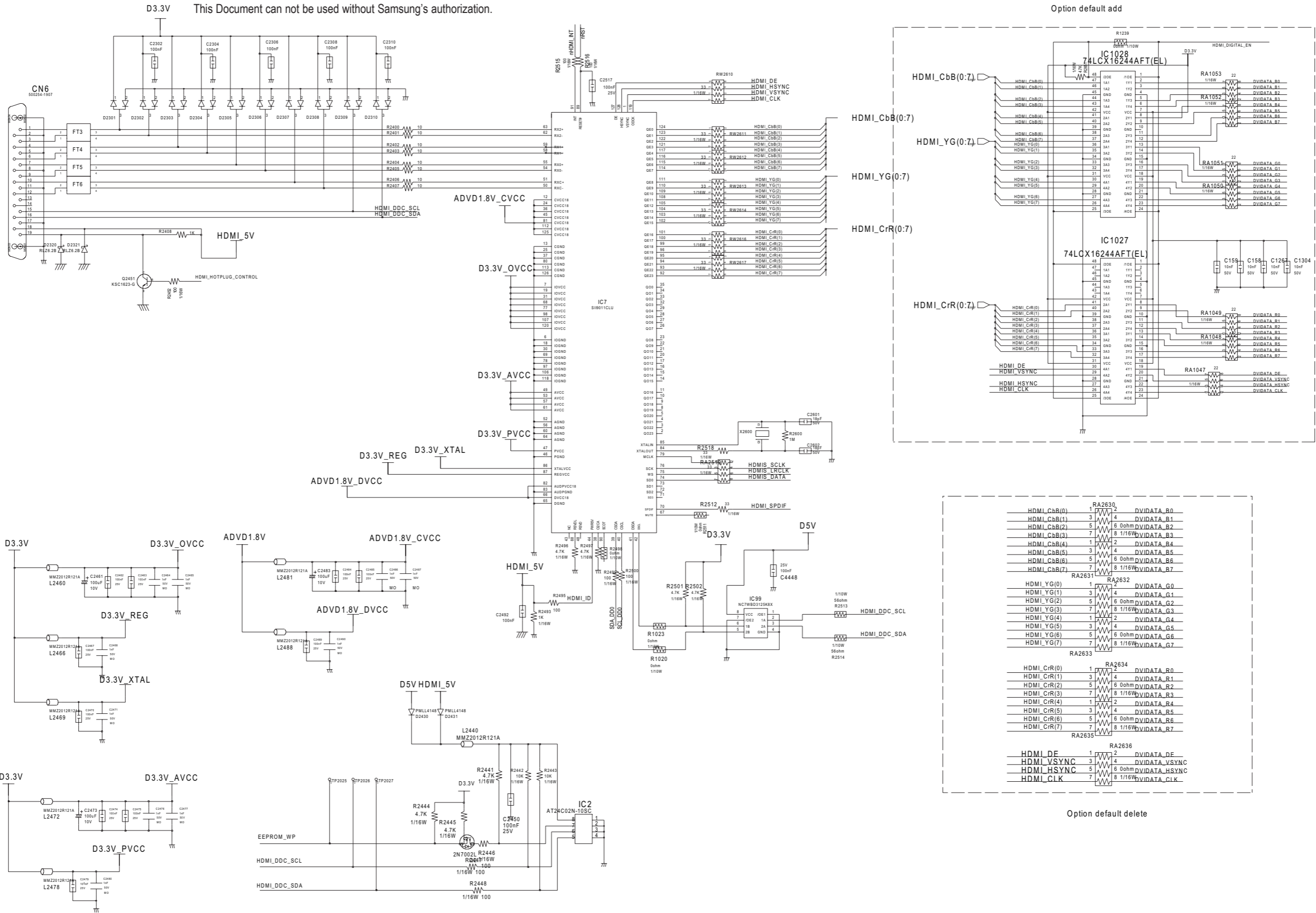

10-2-14 DTV Module-14

This Document can not be used without Samsung's authorization.

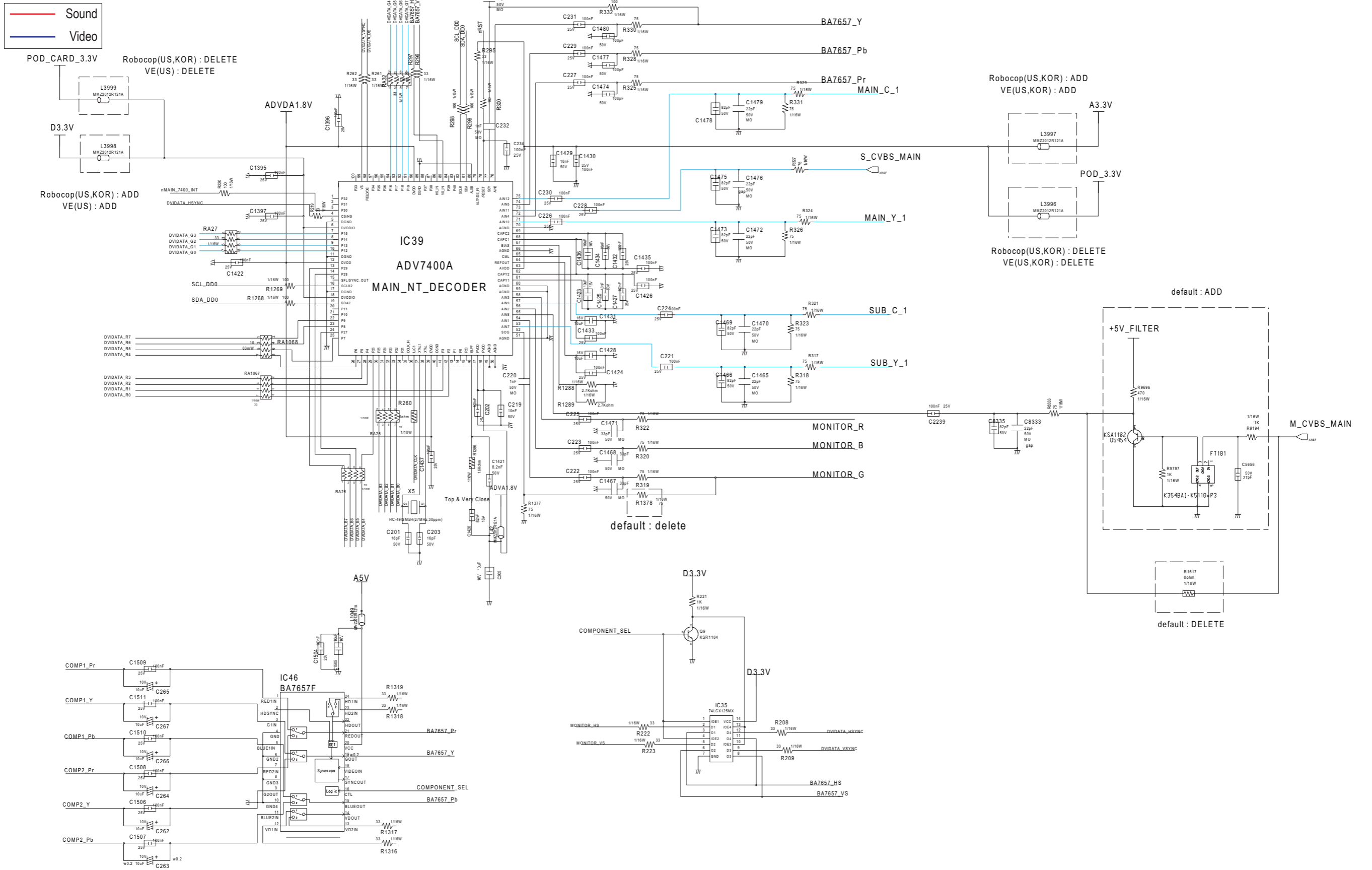

10-2-17 DTV Module-17

This Document can not be used without Samsung's authorization.

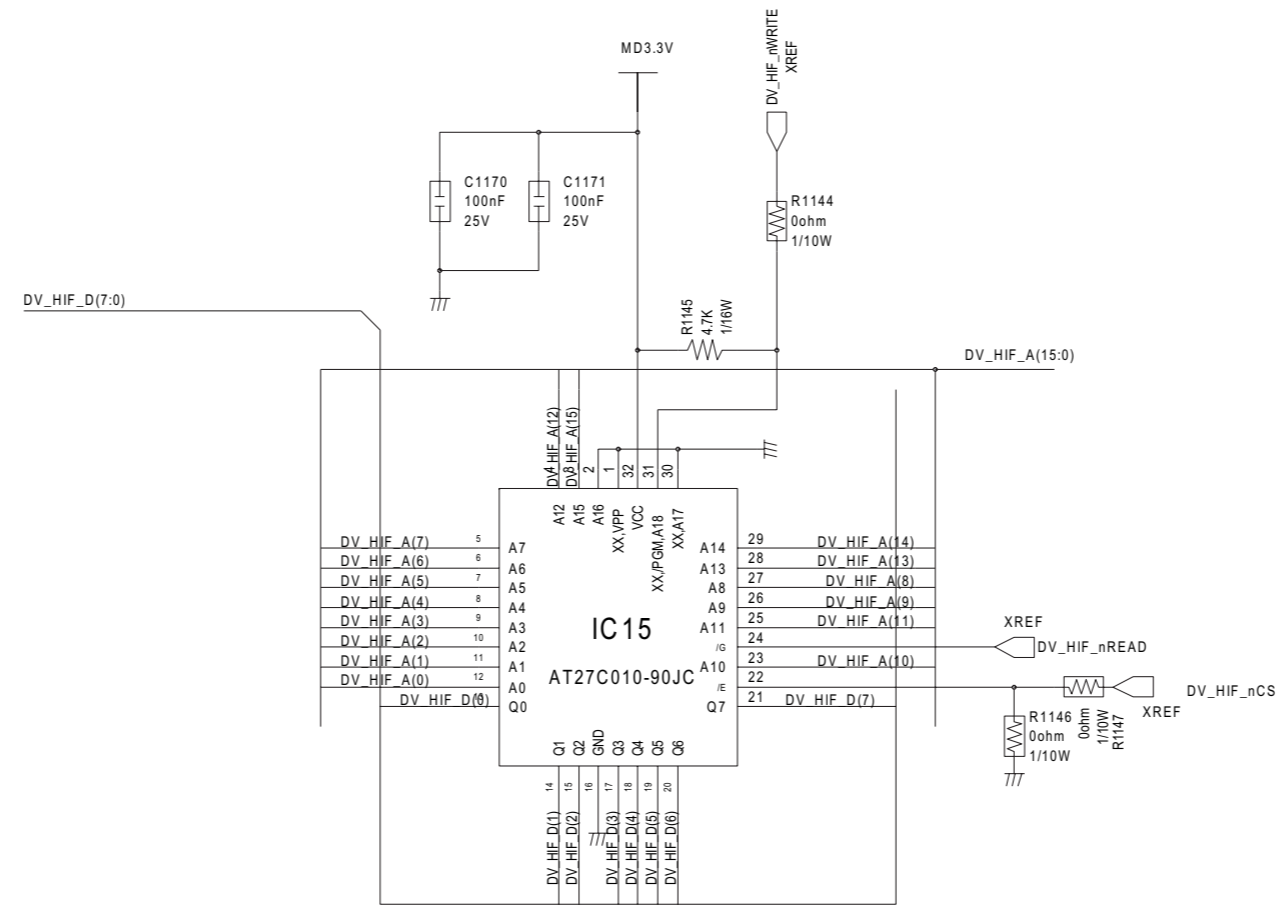

10-3-4 DMD Board-4

This Document can not be used without Samsung's authorization.

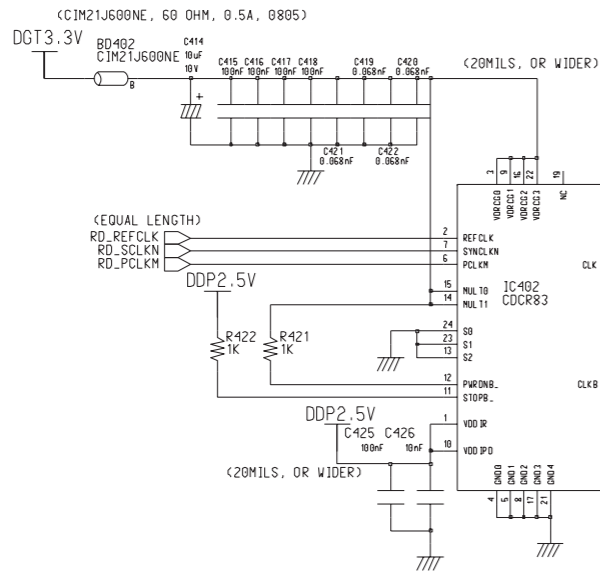
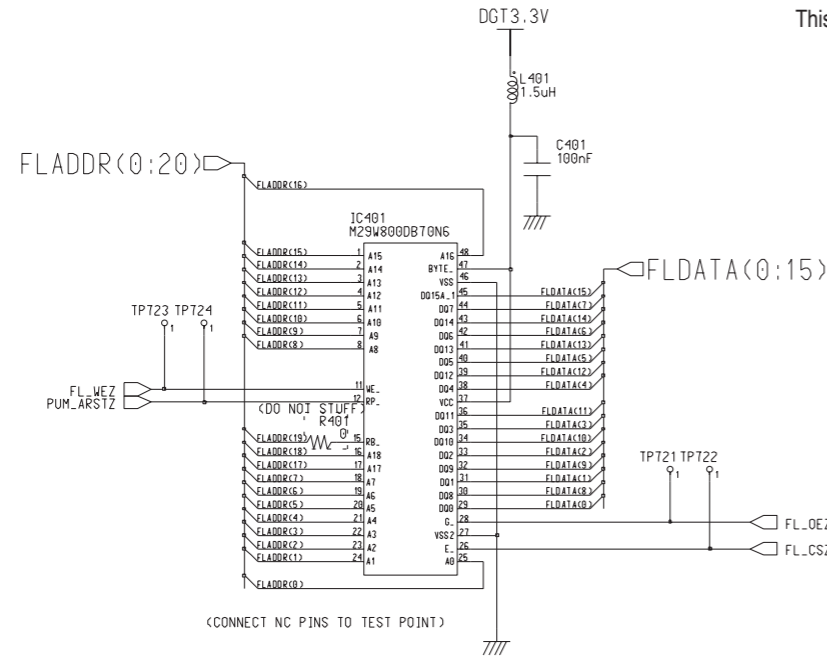

<PAIR, IMPEDANCE: UNLOADED :40 OHM, LOADED:60.6 OHM>
 <ROUTING: CDCR83-> RDRAM(CTM) -> DDP1010(CFM) -> RDRAM -> TERMINATION RESISTOR)>
 <RSL : RD(0:7), RQA(0:8), ROB(0:8), RD_CTM, RD_CTMN, RD_CFM, RD_CFMN, RD_CMD, RD_SCK)>
 <50 OHM IMPEDANCE : RD_REFCLK, RD_SCLKN, RD_PCLKN)>
 <ALL RSL SIGNALS, SCK, CMD, DIFF CLOCK PAIRS MUST HAVE MATCHED ELECTRICAL LENGTH>

< CHANNEL IMPEDANCE : 40 OHM)>
 <TRACE THICKNESS : 1 OZ CU)>
 <LENGTH OF LOADED SEGMENT : 748 MILS)>
 <TRACE WIDTH FOR UNLOADED SECTION : 10.4 MILS -> DEPENDENT ON VENDOR)>
 <MINIMUM UNLOADED PITCH : 30 MILS)>
 <FINISHED DIELECTRIC THICKNESS : 8 MILS -> DEPENDENT ON VENDOR)>

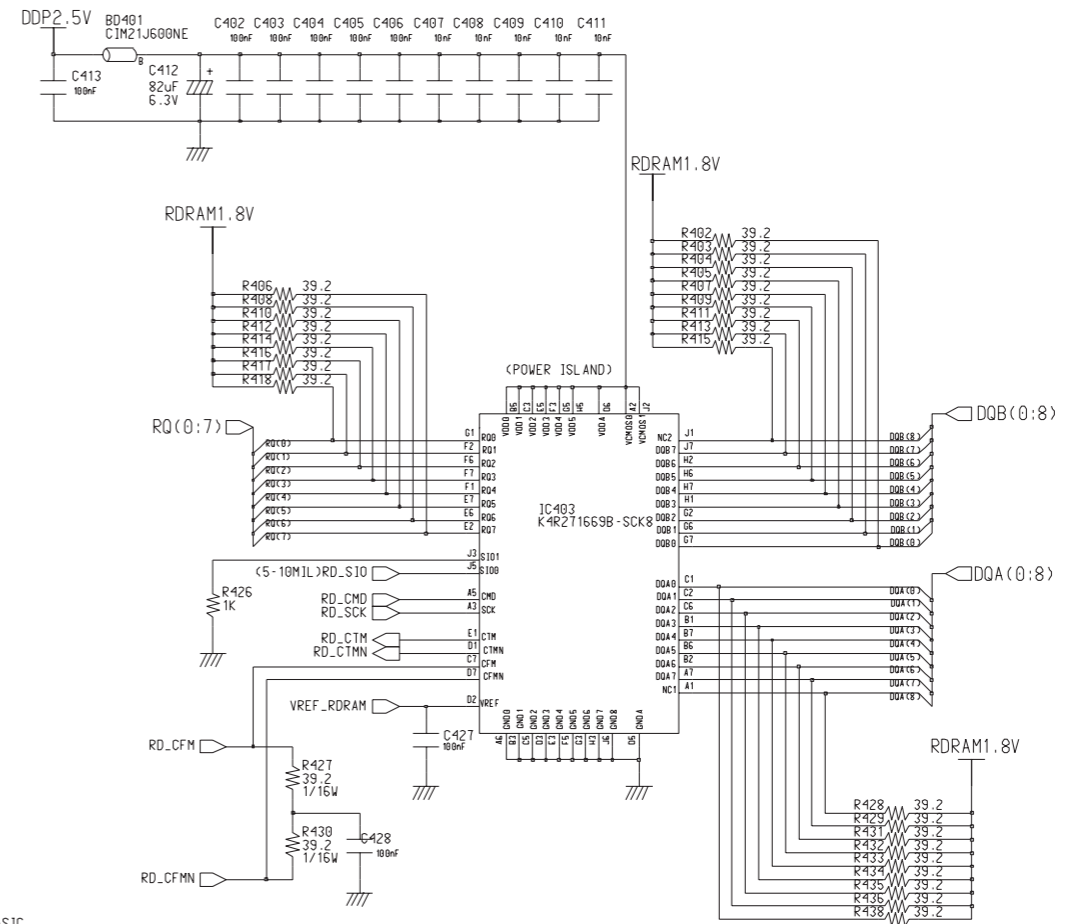
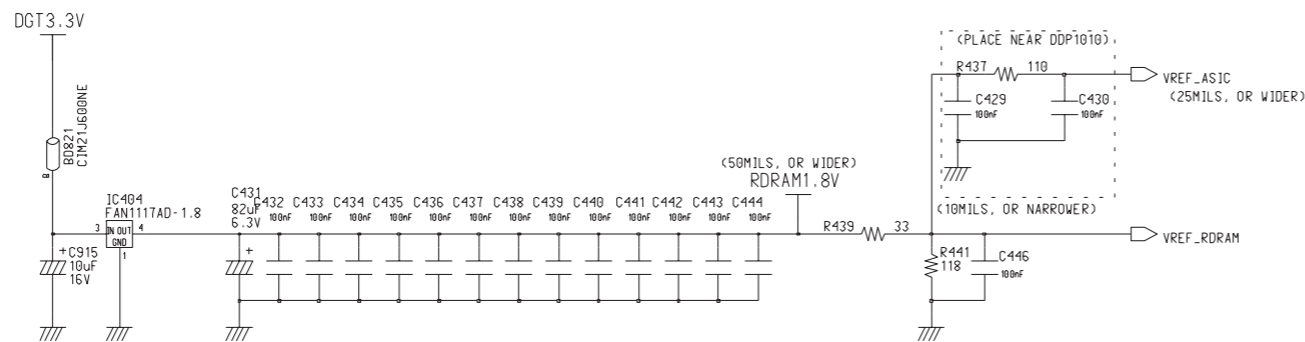

<RDRAM FOR SHORT CHANNEL, 54PIN)>

10-3-5 DMD Board-5

This Document can not be used without Samsung's authorization.

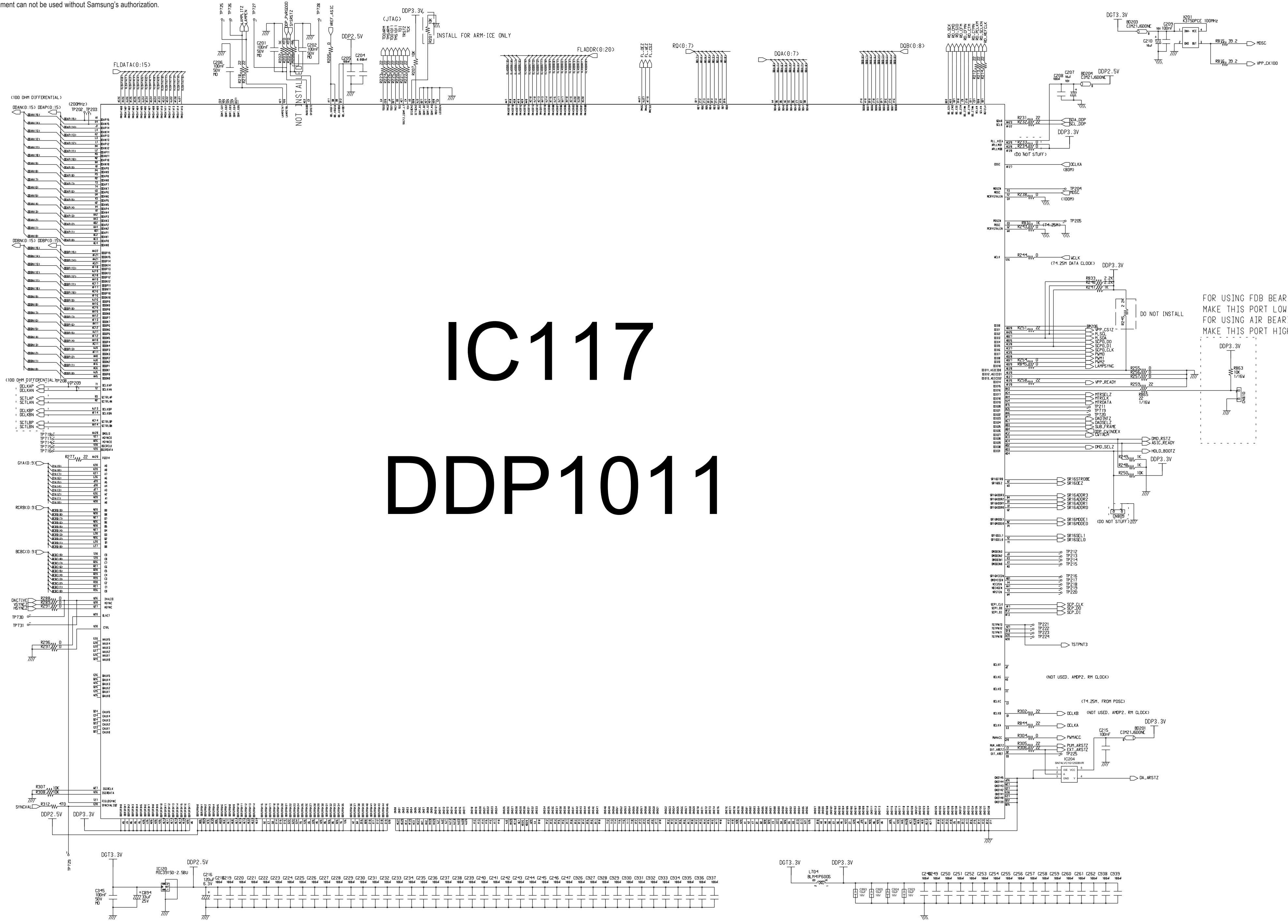

IC117

DDP1011

10-3-6 DMD Board-6

This Document can not be used without Samsung's authorization.

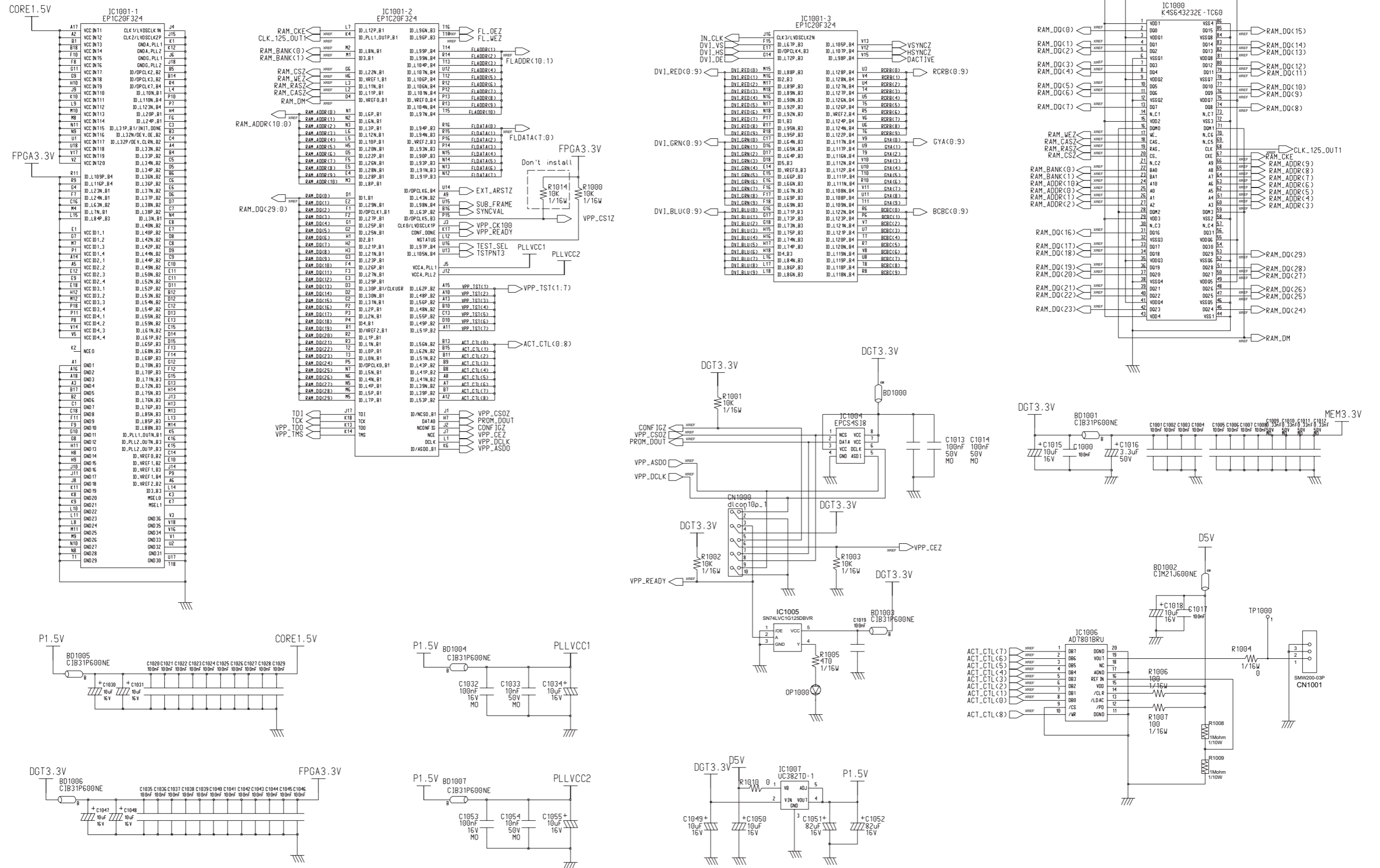

10-3-7 DMD Board-7

This Document can not be used without Samsung's authorization.

(COLOR WHEEL SENSOR DETECTION)

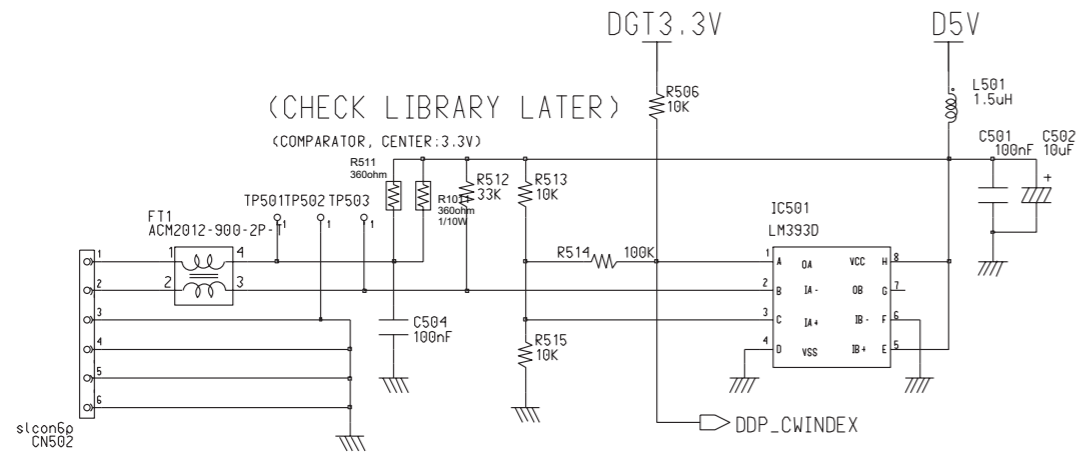

(LAMP CONTROL)

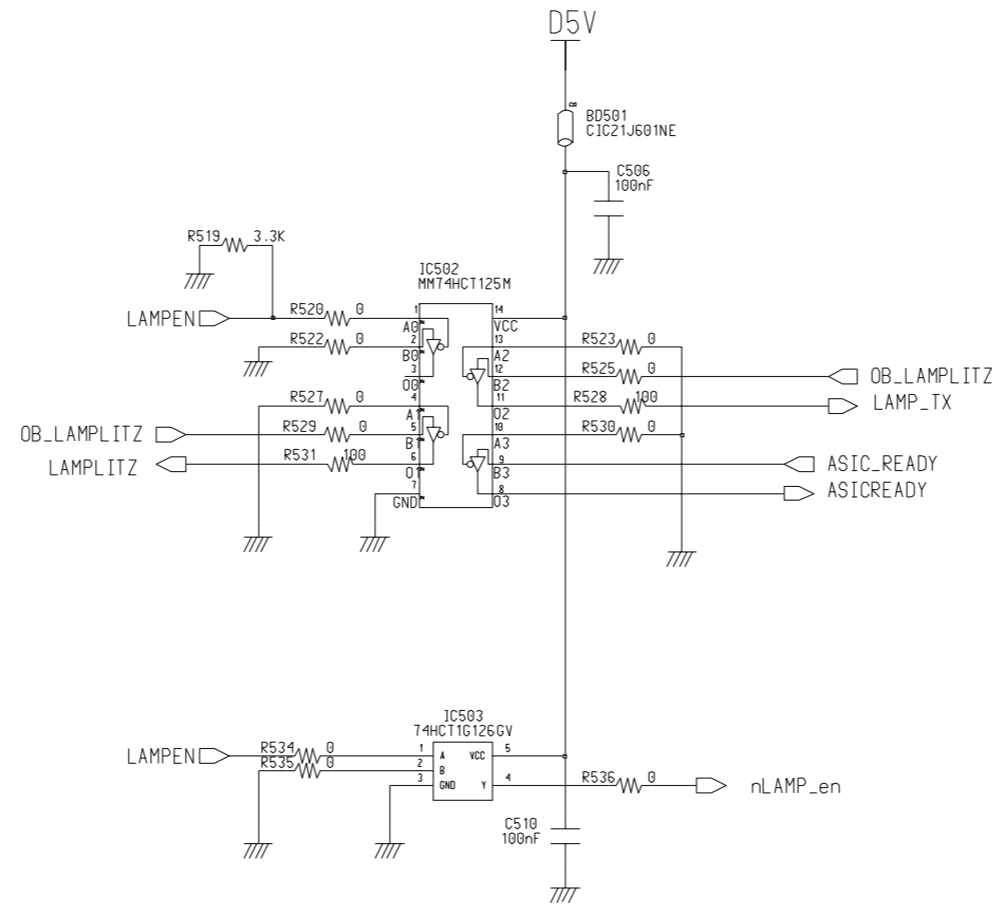

For Ballaster by Tho/Osr

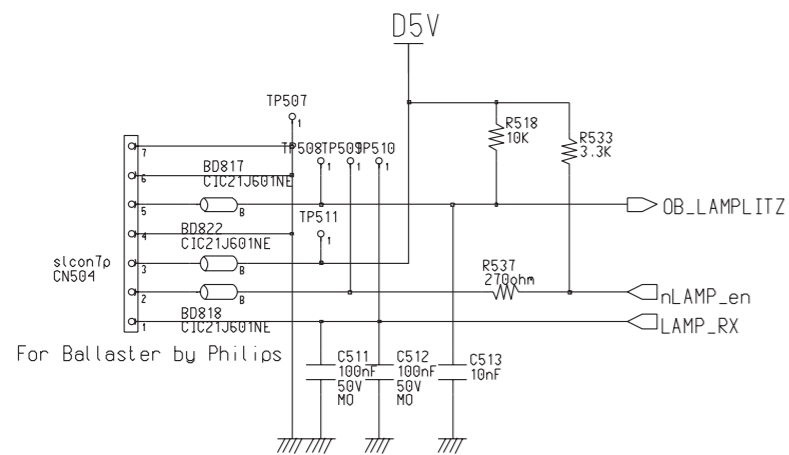

For Ballaster by Philips

JTAG Configuration	R505	R830
Normal Operation	Not Installed	Installed
ARM-ICE Debug	Installed	Not Installed

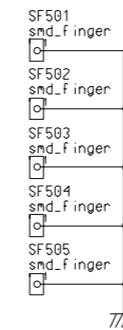
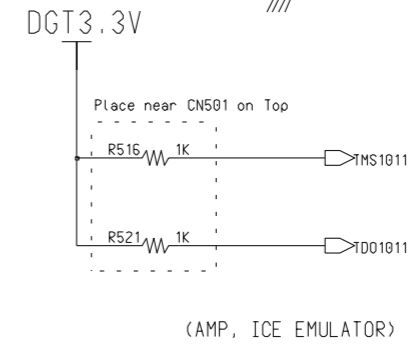
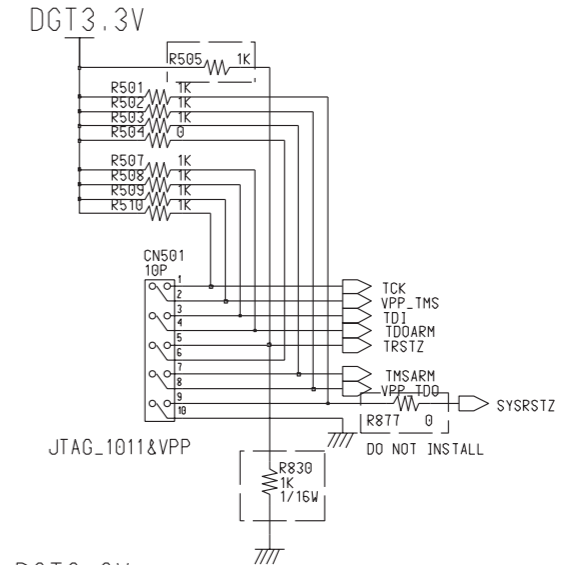

10-4 Actuator Board

This Document can not be used without Samsung's authorization.

(SIGNAL FROM ANALOG BOARD)

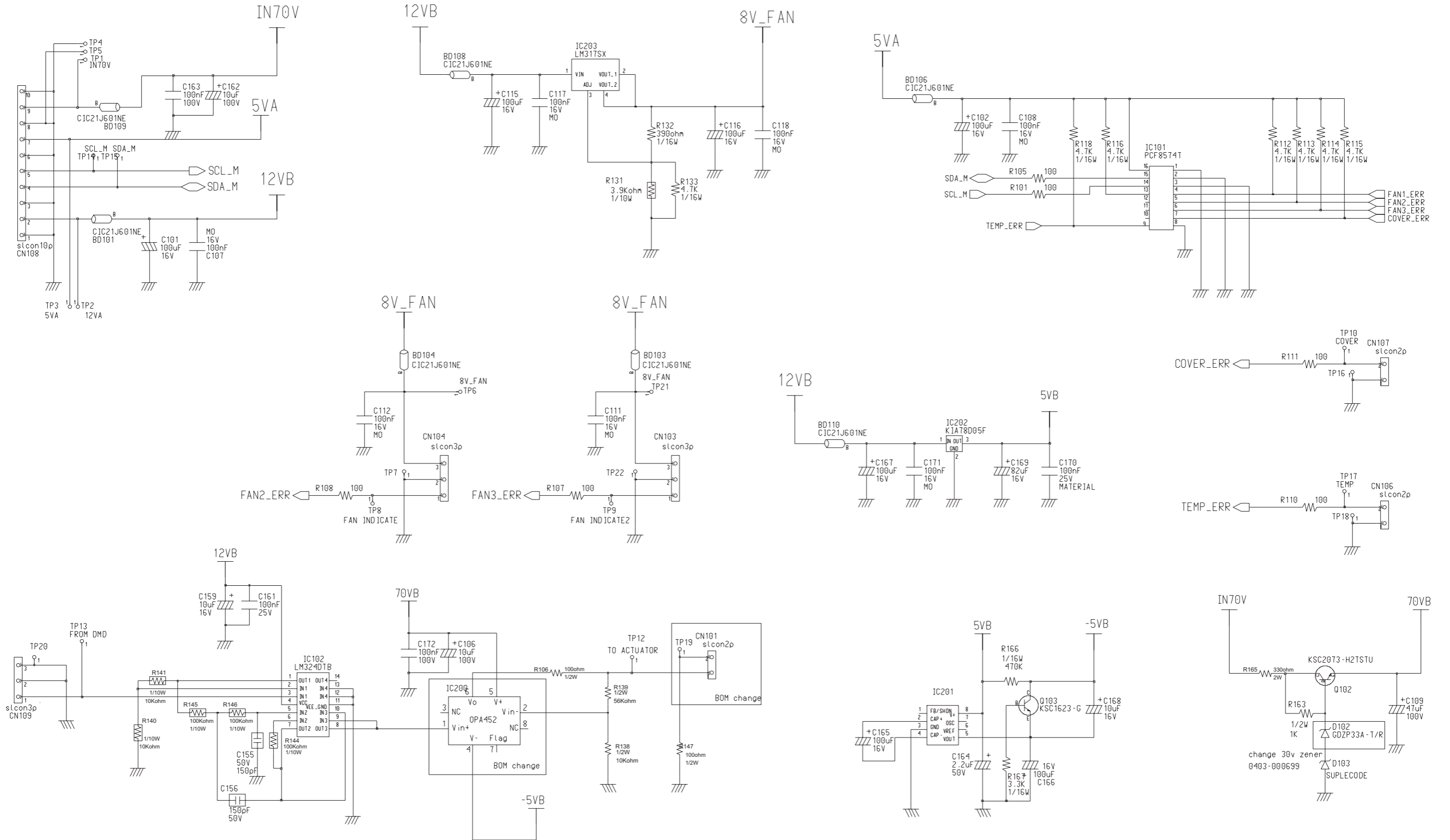

10-6 Power Board

This Document can not be used without Samsung's authorization.

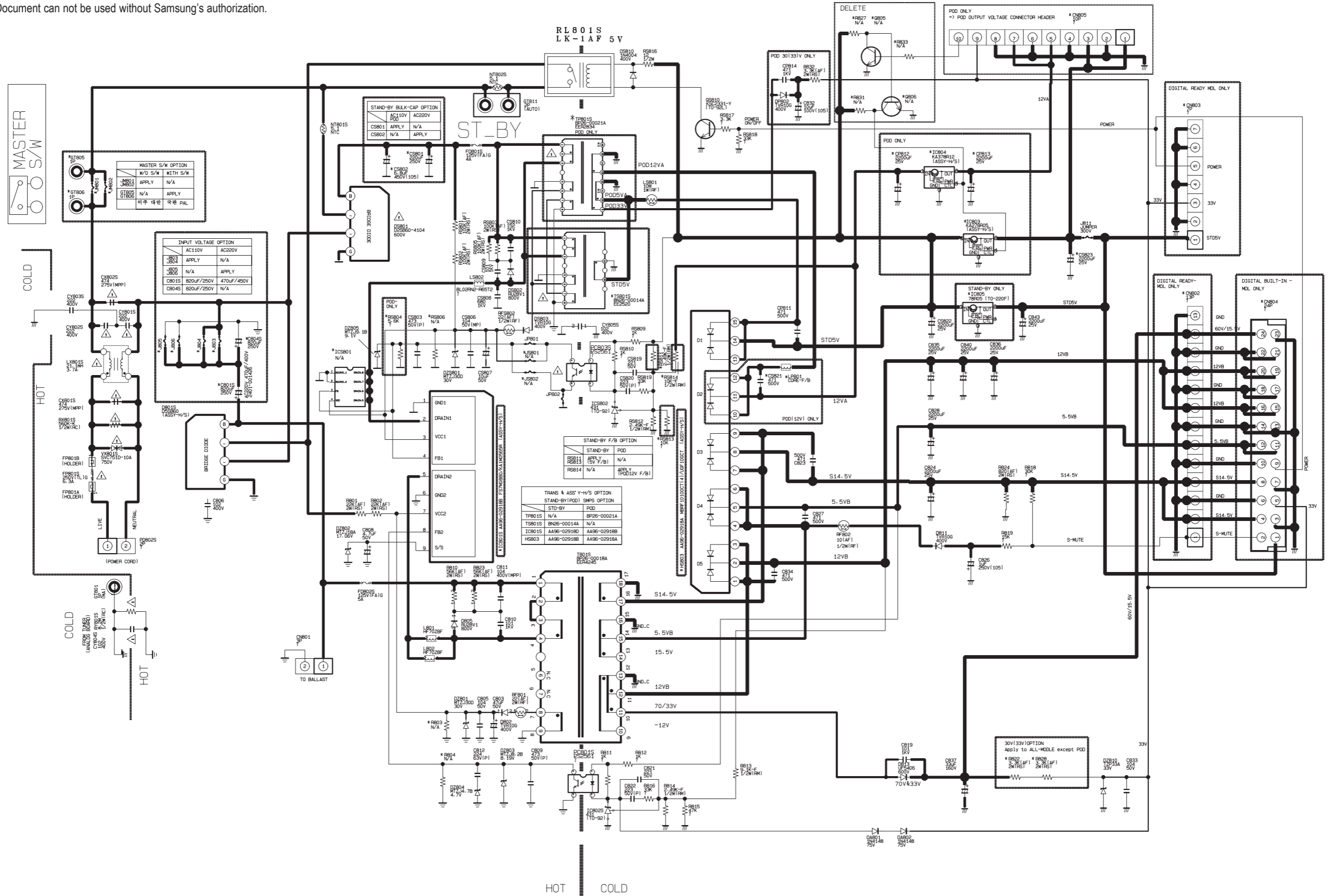

10-7 Combined Bridge and Control Module

This Document can not be used without Samsung's authorization.

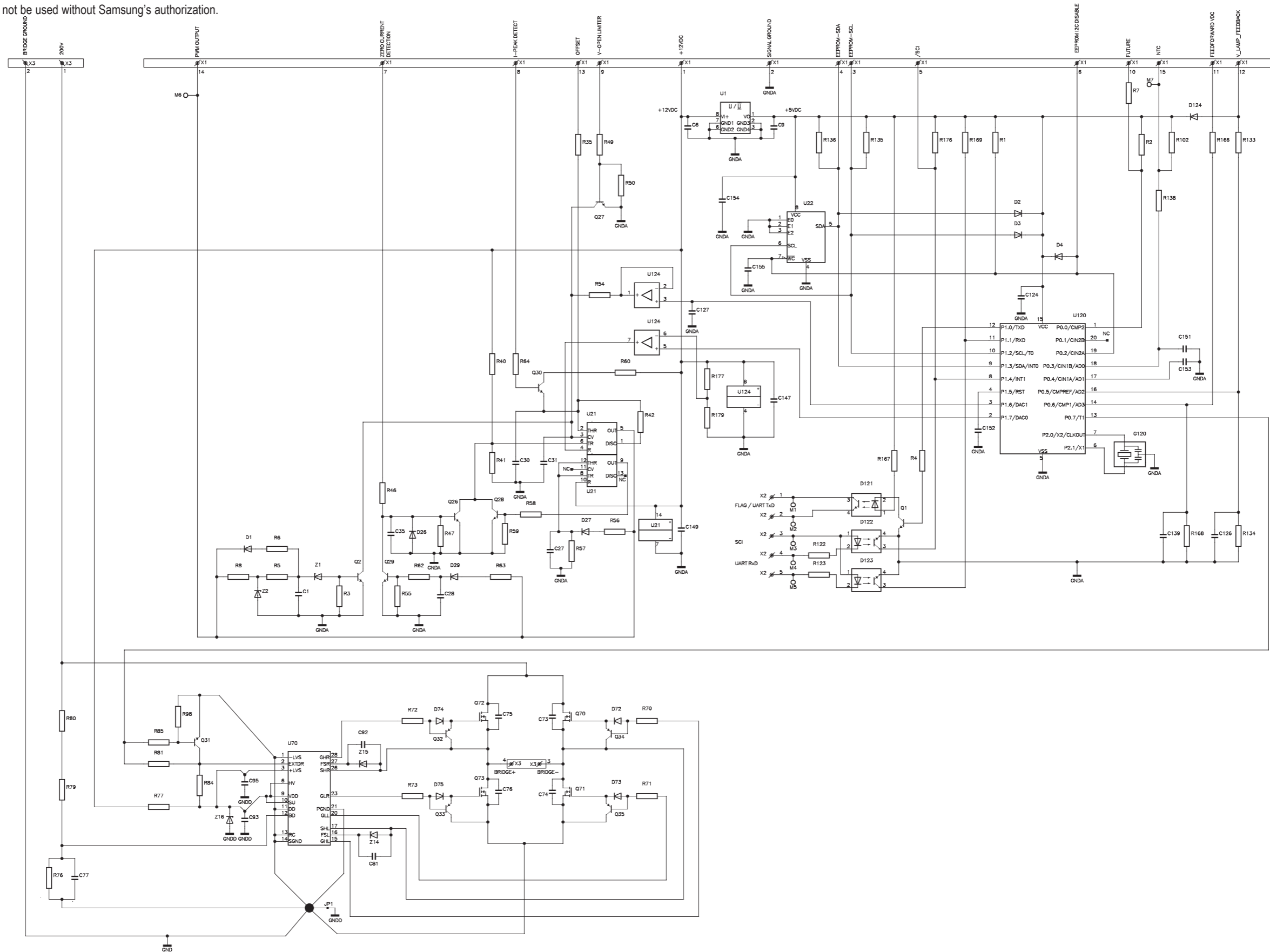

10-8 Detect

This Document can not be used without Samsung's authorization.

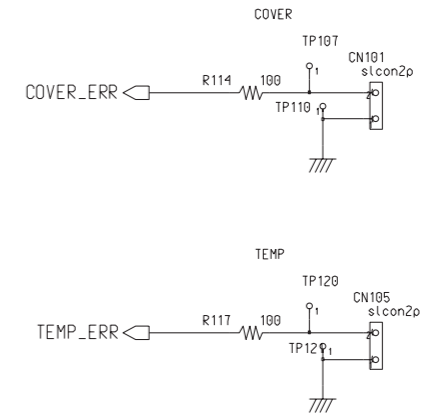
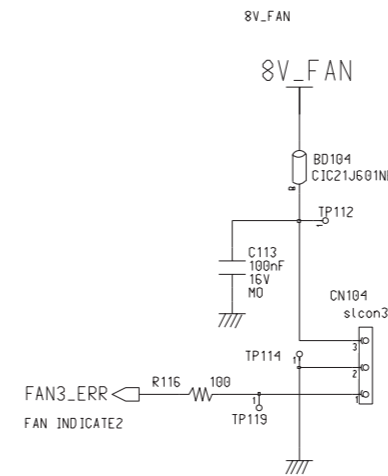
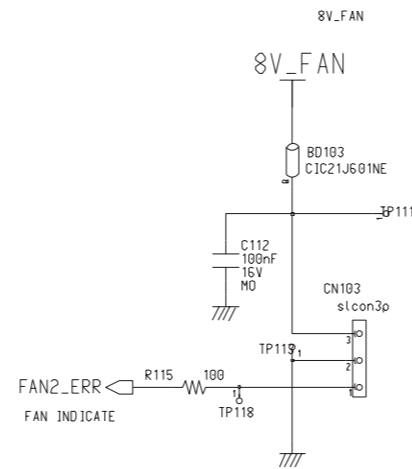
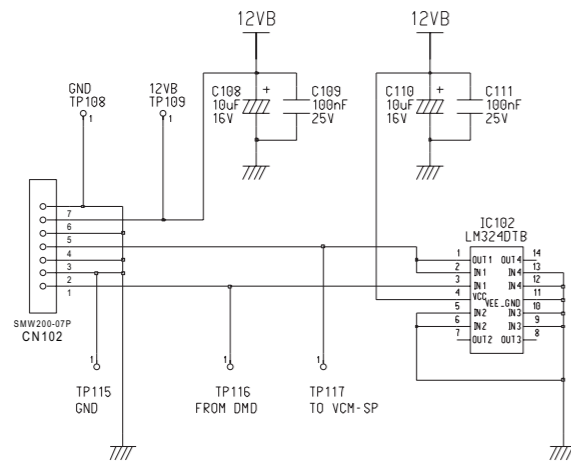
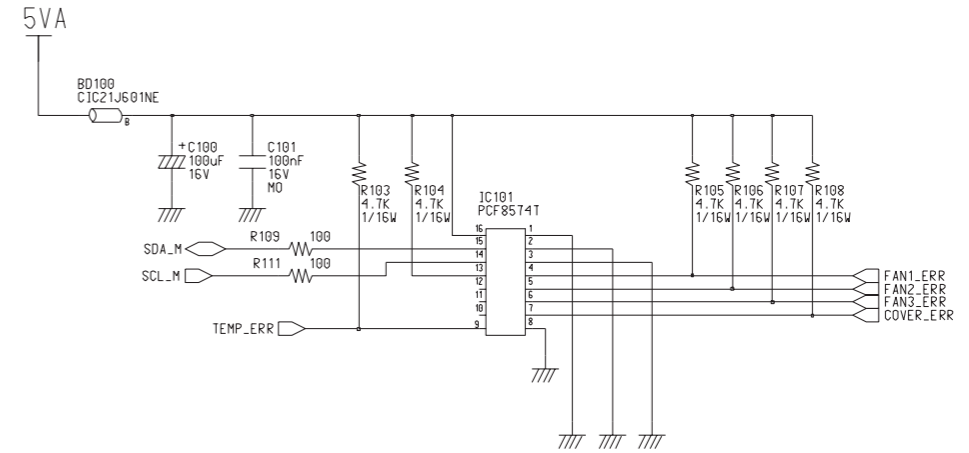
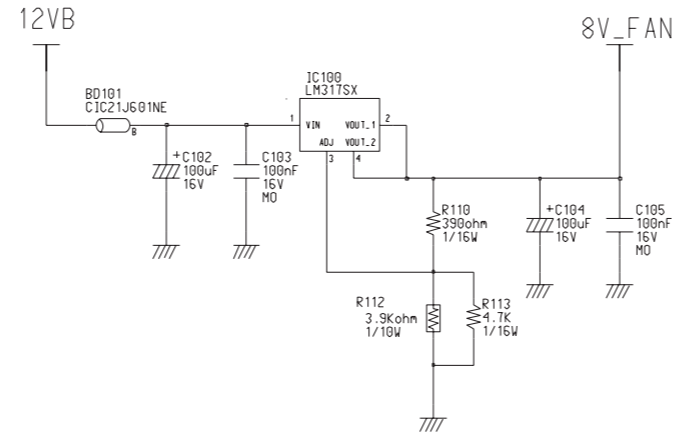
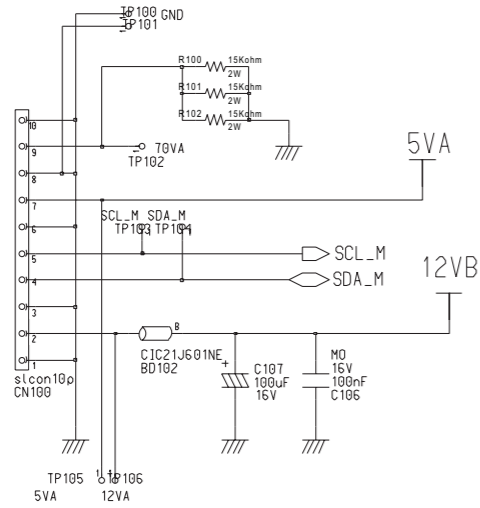

9. PCB Diagram

9-1 Power Board

9-1-1 Assy Power Board

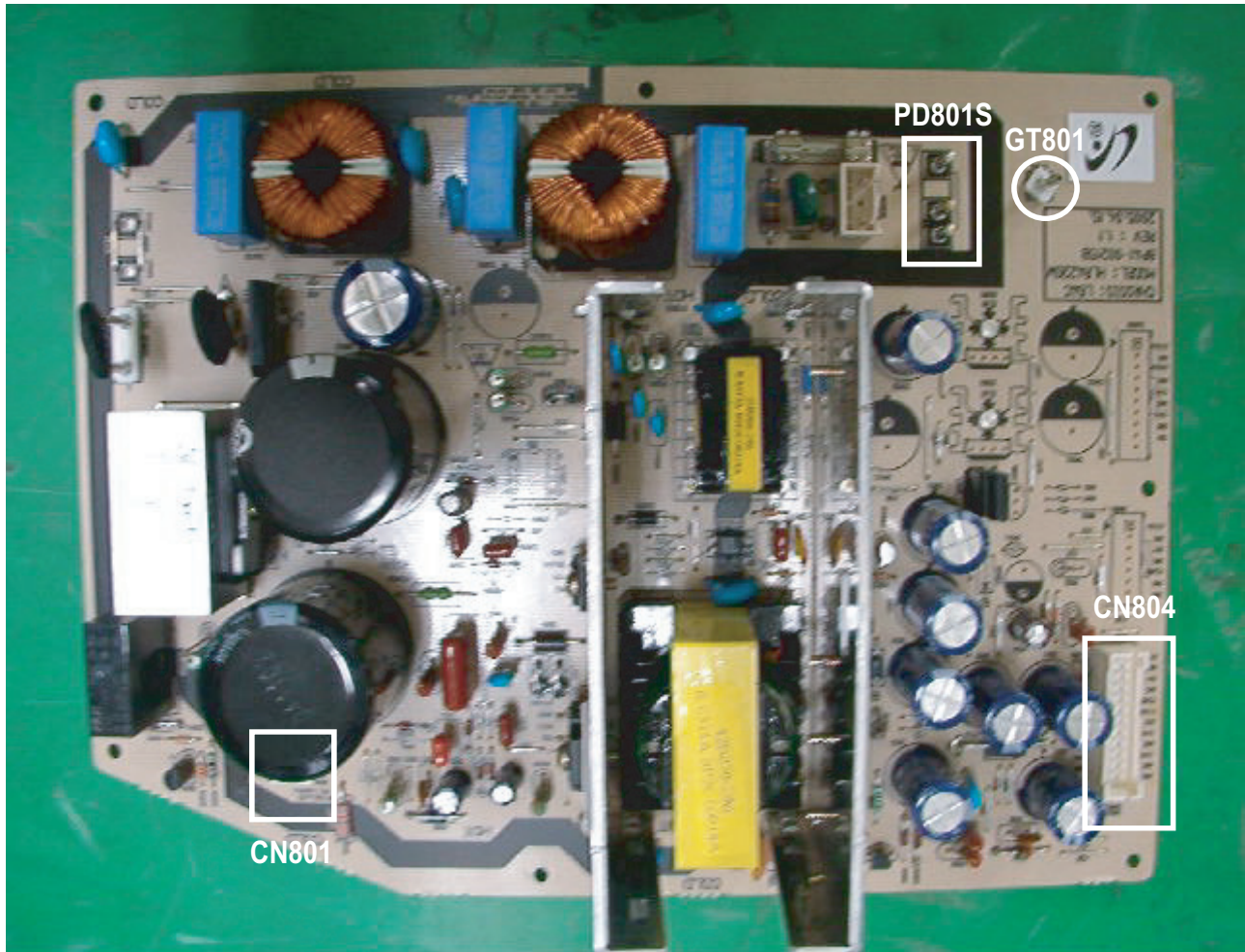

■ DC Power Supply

(Supplies DC power to the analog PCB. The analog board is responsible for the power supply to the digital/DMD board.)

9-1-2 Names & Roles of Key Parts

- * CN801 : Supplies power (DC330V \pm 10%) to the ballast.
- * GT801 : Anti-lightning wire connected to the digital board. The anti-lightning wire should be installed for safety purposes.
- * PD801S : Connecting with power cable.

9-1-3 Power Board Connector Pin

CN804

Connecting Power to Analog Board

Pin Name	PIN No.		Pin Name
STD 5V	1	2	S-MUTE
GND	3	4	S14.5V
33V	5	6	GND
GND	7	8	S14.5V
POWER-SW	9	10	GND
5.5VB	11	12	5.5VB
GND	13	14	GND
12VB	15	16	12VB
GND	17	18	GND
12VB	19	20	12VB
GND	21	22	GND
GND	23	24	80VB

9-2 Digital Board

9-2-1 Assy Digital Board

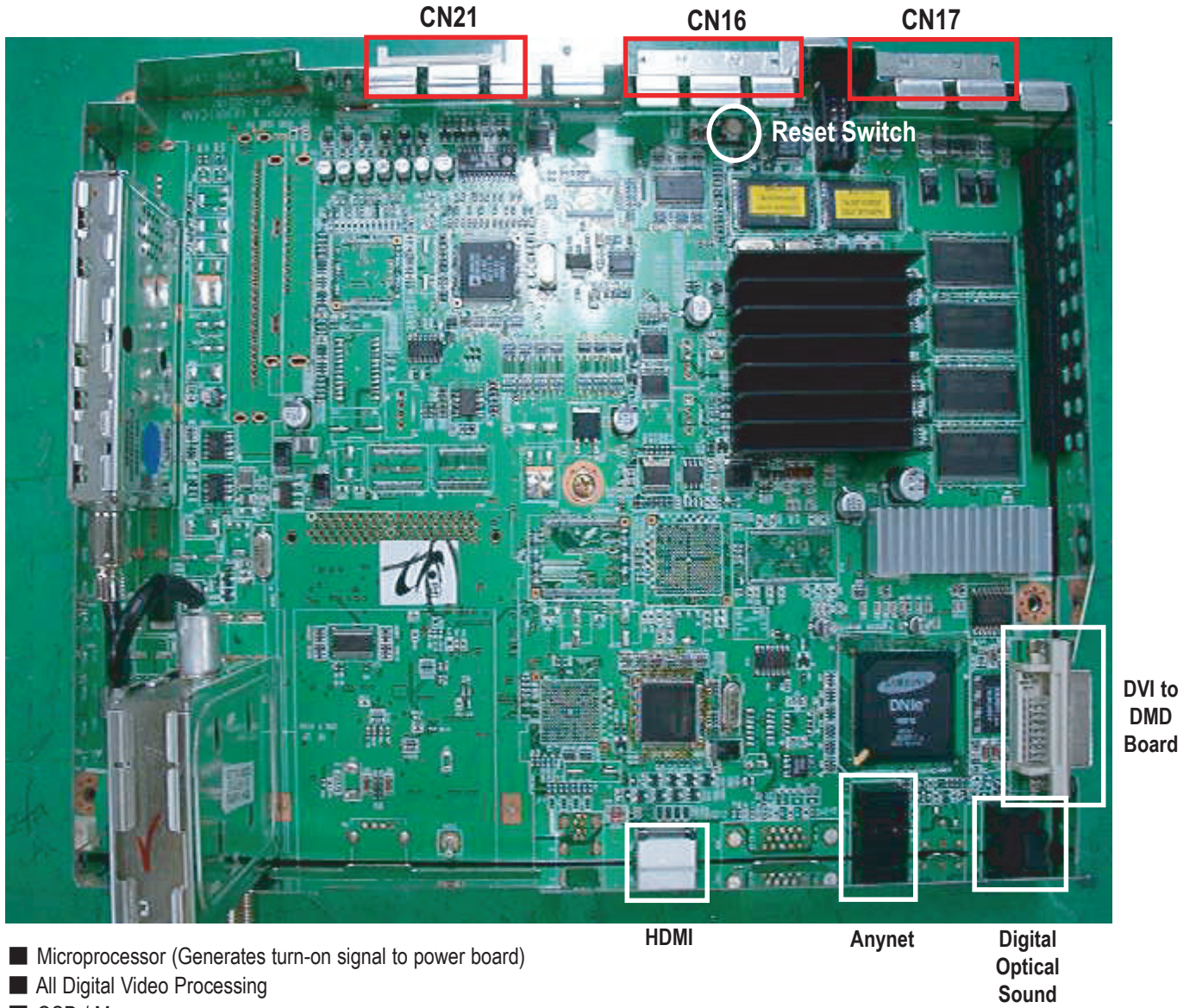

9-2-2 Names & Roles of Key Parts

* High Definition Multimedia Interface :

The HDMI™ (High Definition Multimedia Interface) supports uncompressed standard and high definition digital video formats and existing digital multi-channel audio formats.

* G-Link :

This jack is used by the TV Guide On screen system of the TV to control external analog devices such as VCRs, DVDs, cable boxes, satellite receivers and audio receivers.

* D-Net(IEEE1394) :

These jacks allow the TV to connect to external IEEE 1394 digital products by means of a single cable.

9-2-3 Digital Board Connector Pin

CN16

Connecting the control signal between Digital & Analog Board

Pin Name	PIN No.		Pin Name
I2SWS_OUTA	1	2	TxDM
I2SSD_OUTA	3	4	RxDM
I2SCLK_OUTA	5	6	GND
GND	7	8	SDA_M5
SDA_PANNEL	9	10	SCL_M5
SCL_PANNEL	11	12	NT_I2S_SCLK
GND	13	14	NT_I2S_LRCLK
NT_I2S_DATA	15	16	USB_SW_UP_P
nMICOM_INIT	17	18	USB_SW_UP_N
nRESET	19	20	S_nRESET
ANALOG-nRST	21	22	DDP_READY
MD-nRESET	23	24	PWRGOOD
LAMP-ERROR	25	26	DTV_Lt
DLP-SYNCVAL	27	28	DTV_Rt
GND	29	30	GND

CN17

Connecting Power to the Digital Board

Pin Name	PIN No.		Pin Name
MD3.3V	1	2	MD3.3V
MD3.3V	3	4	D3.3V
GND	5	6	D3.3V
GND	7	8	GND
STB_6.5V	9	10	GND
GND	11	12	GND
STB_9V	13	14	D5.7V
GND	15	16	D5.7V
STB_30V	17	18	GND
STB_5V	19	20	GND
5VA	21	22	D12V
GND	23	24	GND
GND	25	26	D9V
33V	27	28	GND

CN21

Connecting the Audio/Video signal from the rear input terminal

Pin Name	PIN No.		Pin Name
MAIN_Y	1	2	GND
MAIN_C	3	4	GND
SUB_Y	5	6	GND
SUB_C	7	8	GND
DTV_CVBS	9	10	GND
COMP1_Y	11	12	GND
COMP1_Pb	13	14	GND
COMP1_Pr	15	16	GND
COMP2_Y	17	18	GND
COMP2_Pb	19	20	GND
COMP2_Pr	21	22	GND
M-CVBS	23	24	GND
M-SIF	25	26	GND
S-CVBS	27	28	GND
S-SIF	29	30	GND

9-3 Analog Board

9-3-1 Assy Analog Board

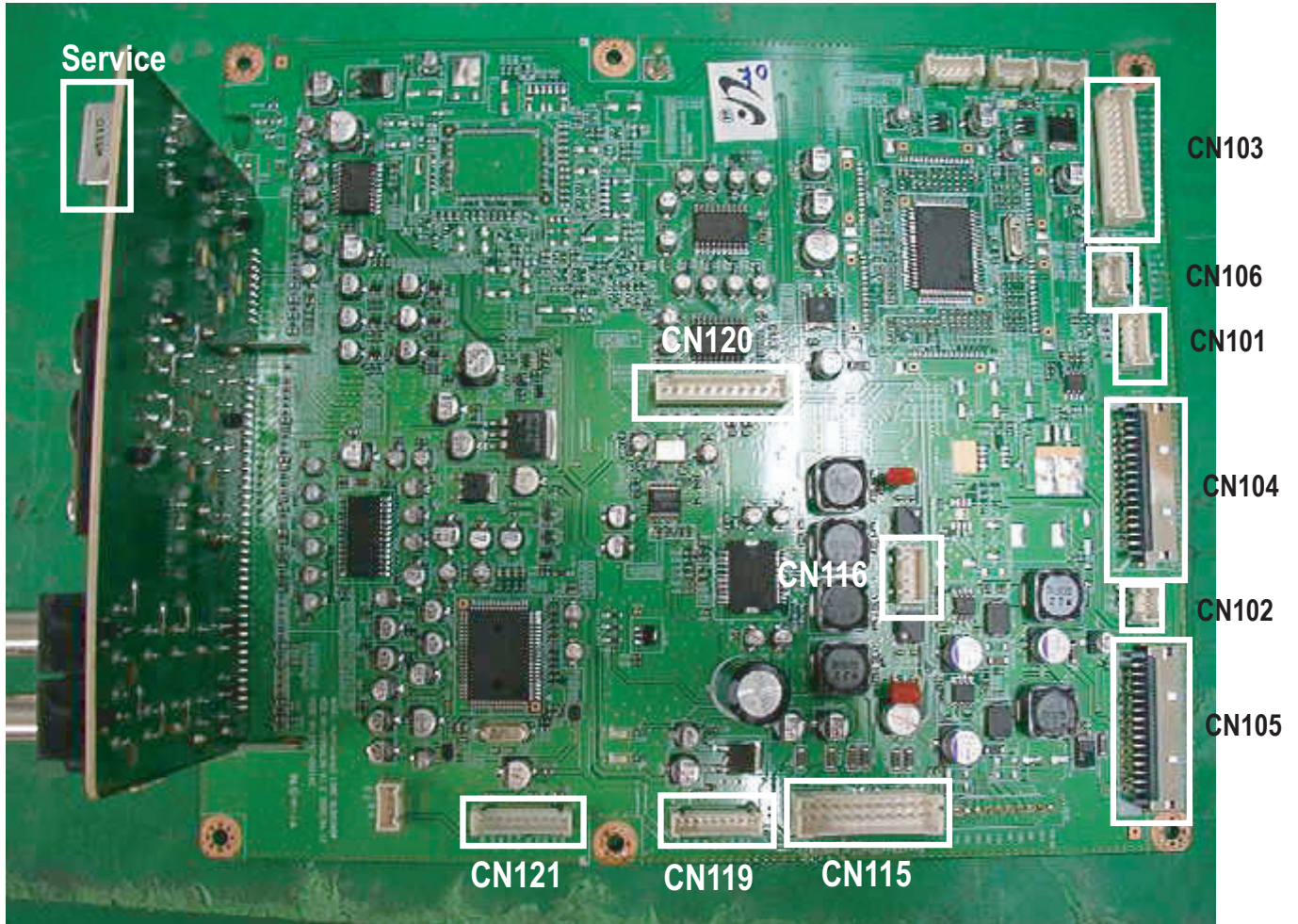

- Distributes supply voltage from the Power Board to Digital Board and DMD Board.
- Transfers Turn-on Command to Digital and Power Board.
- Encompasses the majority of the Audio Circuit
- Analog Video Switching / Processing
- Analog Audio Switching / Processing

9-3-2 Names & Roles of Key Parts

- * CN121 : Connected to the actuator board
- * CN119 : Connected to the DMD board
- * CN115 : Connected to the power board - receives the second power source generated on the power board.
- * CN105 : Sends the power source from the analog to the digital board.
- * CN104 : This is a control signal terminal that connects between the analog and digital boards.
- * CN103 : This is an AV signal terminal that connects between the analog and digital boards.

9-3-3 Analog Board Connector Pin

CN119

Connecting Power to the DMD

Pin No.	Pin Name
1	5VB
2	5VB
3	GND
4	GND
5	12VB
6	12VB
7	GND
8	GND
9	GND

CN106

Connecting Side Buttons

Pin No.	Pin Name
1	GND
2	KEY1
3	KEY2
4	GND

CN105

Connecting Power to the Digital Board

Pin Name	PIN No.		Pin Name
3.3V-ATI	1	2	3.3V-ATI
3.3VB-D	3	4	3.3V-ATI
3.3VB-D	5	6	GND
GND	7	8	GND
GND	9	10	6.5VA-D
GND	11	12	GND
5.7VB	13	14	9VA
5.7VB	15	16	GND
GND	17	18	30VA
GND	19	20	5VA
12VB	21	22	5VA
GND	23	24	GND
9VB	25	26	GND
GND	27	28	33VB
GND	29	30	GND

CN123

For Debugging

Pin No.	Pin Name
1	SDA-A
2	SCL-A
3	GND
4	5VA

CN121

Connecting Power and the Control Signal to the Actuator Protection Board

Pin No.	Pin Name
1	GND
2	12VB
3	GND
4	SDA-M1
5	SCL-M1
6	GND
7	5VA
8	GND
9	70VB
10	GND

CN102

Connecting the IR signal

Pin No.	Pin Name
1	IR
2	GND
3	5VA

CN101

Connecting front LED indicators

Pin No.	Pin Name
1	5VA
2	KEY-PWR
3	GND
4	LED1
5	LED2
6	LED3

CN116

Connecting and transmitting Audio signal to Speaker

Pin No.	Pin Name
1	-L-OUT
2	+L-OUT
3	-R-OUT
4	+R-OUT

CN105

Connecting Power

Pin Name	PIN No.		Pin Name
5VA	1	2	POWER-MUTE
GND	3	4	S16VB
33VB	5	6	GND
GND	7	8	S16VB
POWER-SW	9	10	GND
5.7VB	11	12	5.7VB
GND	13	14	GND
12VB	15	16	12VB
GND	17	18	GND
12VB	19	20	12VB
GND	21	22	GND
GND	23	24	70VB

CN103

Connecting the Audio/Video signal from the rear input terminal

Pin Name	PIN No.		Pin Name
MAIN_Y	1	2	GND
MAIN_C	3	4	GND
SUB_Y_V	5	6	GND
SUB_C	7	8	GND
DTV_CVBS	9	10	GND
COMP1_Y	11	12	GND
COMP1_Pb	13	14	GND
COMP1_Pr	15	16	GND
COMP2_Y	17	18	GND
COMP2_Pb	19	20	GND
COMP2_Pr	21	22	GND
MTNR_CVBS	23	24	GND
MTNR_SIF	25	26	GND
STNR_CVBS	27	28	GND
STNR_SIF	29	30	GND

CN120

Transmitting Video Signal from Side Terminal

Pin No.	Pin Name
1	SIDE-Y
2	SIDE-C
3	GND
4	SIDE-V
5	GND
6	SIDE-L
7	GND
8	SIDE-R
9	GND
10	SIDE-SDET
11	SIDE-VDET

CN104

Connecting the control signal between Digital and Analog

Pin Name	PIN No.		Pin Name
TxDM	1	2	ATI-I2S-WS
RxDM	3	4	ATI-I2S-DATA
GND	5	6	STI-I2S-CLK
SDA_A	7	8	GND
SCL_A	9	10	SDA_DMD
I2SCLK	11	12	SCL_DMD
I2S_WS	13	14	GND
USB_POS	15	16	I2S_DATA
USB_NEG	17	18	CPU_INIT
SOUND_RESET	19	20	CPU_RESET
DDP_READY	21	22	RESET_D
PWRGOOD	23	24	MD_nRESET
DTV_L	25	26	LAMP_ERROR
DTV_R	27	28	DLP_SYNCVAL
GND	29	30	GND

9-4 DMD Board

9-4-1 Assy DMD Board

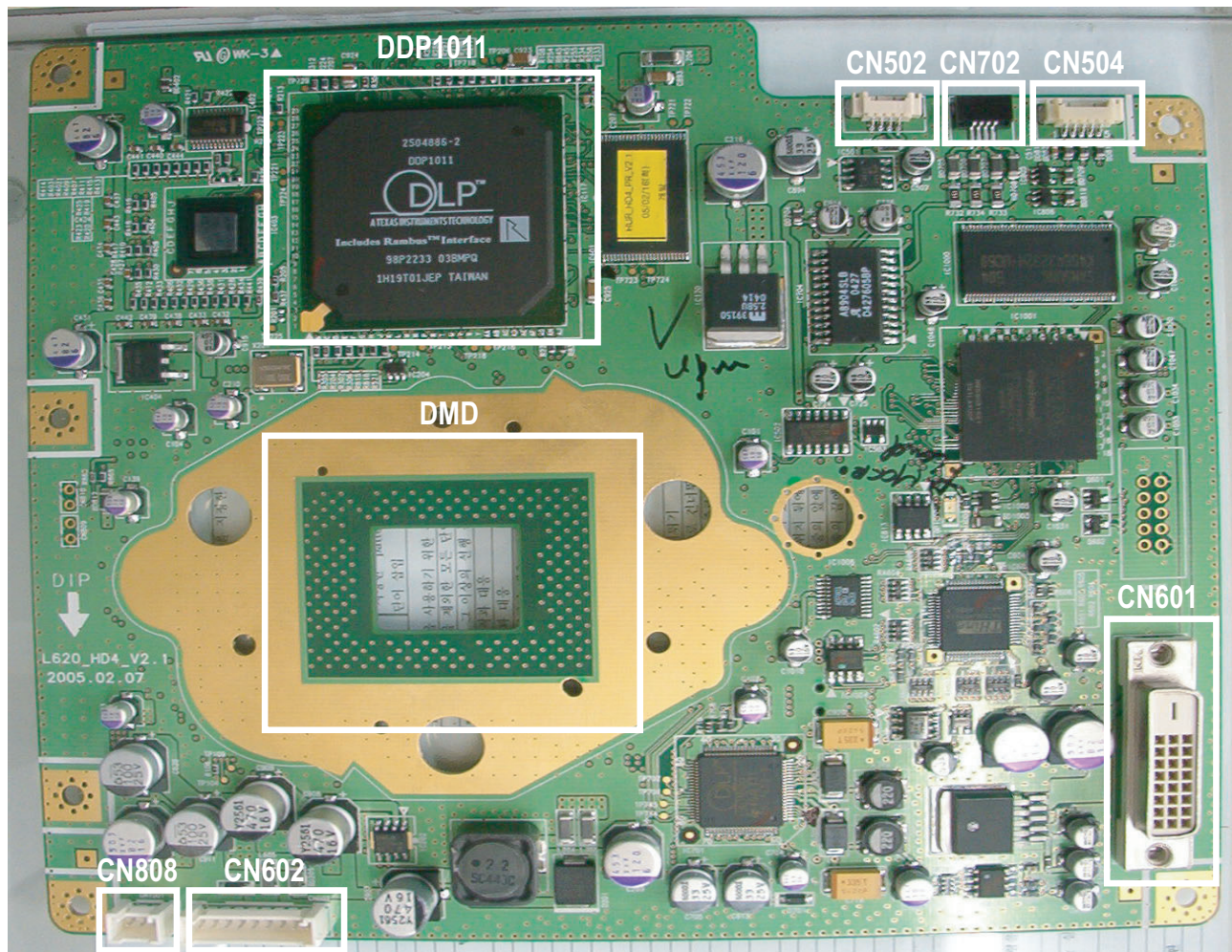

- Controls the lamp (ON/OFF)
- Drives the color wheel motor
- Drives the panel
- Controls the sensors

9-4-2 Names & Roles of Key Parts

- * CN602 : This receives the power source from the analog board and communicates with the I2C.
- * CN808 : This sends a 60Hz signal to the actuator board. The actuator board sends the signal to the actuator module.
- * CN702 : This supplies the power to drive the color wheel.
- * CN502 : This receives the color wheel rotating signals.
- * CN504 : This sends signals to the ballast.
- * CN601 : The DVD cable terminal. This receives the image data from the digital board.
- * DMD PANEL : This is protected with a heat sink and fixtures.
- * DDP1011 : This processes the DMD drive and the signals.

MEMO

14. Reference Information

14-1 Other issues related to other products

Problem	Descriptions
A fixed screen can cause permanent damage to the TV Braun tube.	Braun, PDP and LCD TVs can all be damaged. When a still image is displayed in a sequence, this can leave stains or after-images due to the characteristics of the panel. However, the DLP TV has the advantage that no stains or after-images are left on the screen. The DLP TV has mirror pixels on the DMD panel that project the beam onto the screen, in which the mirror is a digital representation of 0s and 1s, leaving no trace of light. The mirror returns to a blank state so that no stains or after-images are left.
Confusion between the ANYNET Port and the SERVICE Jack Port	The SAMSUNG SKY500N model has both an ANYNET port and a SERVICE jack port. Because the shape of the ANYNET port on the DLP TV is the same as that of the SERVICE jack port of the SKY500N, it fails to turn the TV off after a connection has been reported. The ANYNET port uses an RS232 port called Phone Jack, and the SERVICE jack port also uses the RS232 port. However, you must not connect the SERVICE port and the ANYNET port. Check if the port is the ANYNET port or the SERVICE port before connecting the port. Even if the TV cannot be turned on after connecting, the TV will turn on if you disconnect the connection.
Length of DVI Cable / PC RGB Cable	<p>- A too long DVI cable may cause a malfunction or degradation of the visual quality due to an attenuation of the signal. There is no recommendation for the cable length at present. In general, although a cable length of up to 5 meters should work, please check if video is properly displayed on the screen after connecting. If you think the length of the cable is longer than for normal use, check the visual quality of the video on the screen and shorten the length, if necessary.</p> <p>- This also applies to the PC RGB (D-Sub) cable. When the length of the cable is longer than for normal use, video may not be displayed on the screen. In this case, shorten the cable length.</p>
When a digitally distributed TV user receives HD-rated broadcasts:	The digital distributed TV (Ready Technique) can render HD sources as HD-rated. However, you need to install a set-top box for this purpose. The digital TV alone cannot render HD broadcasting as HD-rated. Install the formal set-top box for HD broadcasts.
When a digital distributed TV user selects normal size (4:3) to receive SD-rated digital broadcasts:	The digitally distributed TV (Ready Technique) renders any broadcasting service as SD-rated. However, when connected to a set-top box, the digital TV renders HD broadcasts as HD-rated and renders SD as SD-rated. The screen size is scaled to 4:3.
When a digitally built-in TV user receives SD (air) broadcasting:	The digitally integrated TV ("built-in" type) renders SD broadcasting as SD-rated. This can be understood easily. Even a high-resolution TV cannot improve a low resolution picture into high quality. In contrast, an SD-rated TV cannot represent HD broadcasting as HD because the resolution of the TV is lower than the original.
When selecting a picture size of 4:3 in connection with a computer or a multimedia device:	The representation capability of SD or HD-rated depend entirely on the TV set. The HD TV can render HD broadcasting as HD-rated only when it receives HD sources. In the meantime, the HD TV renders SD as SD-rated when it receives SD sources. The picture size has nothing to do with the resolution; TV models like SVP-XXL3HD or SVP-XXL6HD have a size adjustment feature to 16:9, 4:3, Panorama, Zoom1, Zoom2 and Auto Wide. This is about the aspect ratio of the top and bottom boundaries to the overall screen and users can select their preference.

■ SD/HD broadcasts and the TV's display capability are related

1. A digital broadcast should be transmitted in wide screen (an aspect ratio of 16:9) HD. If the broadcasting station converts a conventional program created in normal screen (aspect ratio of 4:3) into a digital signal and broadcasts the signal, the left and right of the picture will not be displayed.

This symptom also appears in other manufacturer's TV's. The three appliance companies are trying to resolve the problem through the Ministry of Information and Communication.

- * When watching an SD (normal) broadcast through a Digital (Wide) TV (480P normal broadcast)
- * When watching an SD (normal) broadcast through a Digital Ready (Wide) TV (Using a set-top-box)
- * When watching an analog (normal) broadcast through a wide TV
(When watching a broadcast after changing the aspect ratio of the TV from 16:9 (wide screen) to 4:3)

2. When watching a DVD title or video tape in wide screen (21:9) through a wide (16:9) TV, watching video from a computer or game console by selecting the aspect ratio to 4:3, or watching video from a DVD, VCR, computer or game console through a wide TV by selecting the aspect ratio to normal (4:3) or wide (21:9), the left and right, or top and bottom of the picture will not be displayed.

This symptom appears in other manufacturer's TV's. The three appliance companies are trying to resolve the problem through the Ministry of Information and Communication.

■ Changing the Order of the Picture Size for 16:9 Display Devices

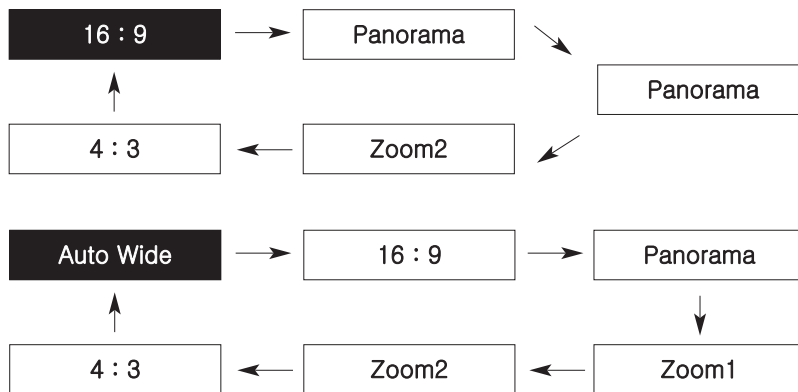

■ Changing the Order of the Picture Size for DTV 1080i/720p Sources



■ Restrictions

1. When you want to change the picture size in PIP 'ON', you must turn the PIP off before changing the size. However, you can change the main picture size even in PIP ON for products with no restrictions.
2. When the picture size is not Normal (4:3 for 4:3 display devices, 16:9 for 16:9 display devices) and you turn PIP on, the picture size is changed to Normal. However, you can turn PIP on without changing the picture size for products with no restrictions.
3. In the OSD notation for the picture size, 16:9 is represented as "Wide" instead of "16:9" for devices other than with 16:9 displays.
Ex: For LCD 15:9 devices, "Wide" is displayed on the OSD instead of "16:9".
4. The picture size can be changed even in the blue screen.
However, the picture size should be controlled by the product specifications if the change is impossible due to hardware restrictions.

14-2 Technical Terms

PIP (Picture In Picture)

A feature to enable two video images being displayed on one screen at the same time. For instance, you can see the TV channel and the video image at the same time.

Digital Broadcasting

The ATSC (Advanced Television Systems Committee) signals that the station digitalizes before transferring the audio/video signals.

Mono

A sound system that transmits voice signals in only one channel. It is hard to experience a 3D effect but can be run with one speaker.

LNA (Low Noise Amplifier)

This uses satellite technologies to amplify weak signals for improved quality even in poor reception areas.

Stereo

A sound system that transmits voice signals in two channels. This implements 3D effects by transmitting to both speakers (left/right).

Analog Broadcasting

The conventional system in which the station transfers the audio/video signals in NTSC formats.

Antenna Terminal

A terminal which the TV antenna is connected to. A round coaxial cable is connected to this terminal, which is usually used to watch air broadcasts.

English Captions (Subtitle)

A feature to provide English captions or character information services, which the user can use to study English using AFKN broadcasting or video tapes marked with "CC".

Audio/Video Terminal

The old 3- or 4-channel TV with no AV terminal has a low quality issue for video tape. The problem can be resolved using an A/V terminal that separates the audio and video signals. The video terminal is in yellow; the audio terminal is divided in two, white for left and red for right.

External Source

This includes sources from the video recorder, DTV set-top box and DVD player, (anything but the TV).

DVI-I Cable

One of the DVI cables that can transfer both digital and analog signals.

Satellite Broadcasting

This uses a satellite system to support a maximum of 100 channels including air services and provides high quality pictures anywhere in the country, even in poor reception areas. A set-top box (unbundled) is required to watch satellite broadcasting.

Closed Broadcasting

Other than VHF and UHF, this includes movies, entertainment and educational programs broadcast by hotels or schools. This is different from cable broadcasting.

Multiplexing

Two languages are provided at the same time when broadcasting foreign movies, dramas and news programs. You can choose either a native or foreign language, or choose both at the same time.

Component Terminal (Green, Blue, Red)

This provides maximum quality by dividing the contrast signals before transferring.

Cable Broadcasting

Compared to air broadcasting, it uses the cable system to transfer the signals. You should subscribe to a local cable broadcasting company and install a separate receiver.

Tuner

A device used to select a particular frequency from the TV set or the radio receiver.

Anynet

An AV networking system of Samsung's various AV devices, which enables the user to conveniently control AV devices using the TV.

DVD (Digital Versatile Disc)

This is a CD-sized, high storage disk that can store multimedia data including videos, games and audio applications using MPEG-2 compression technology.

DVI (Digital Visual Interface) Terminal

This is a digital signaling standard.

This uses TMDS to reduce the signal loss rate for sharper images.

DVI-D Cable

One of the DVI cables that can only transfer digital signals.

HDMI (High Definition Multimedia Interface)

An interface into which the digital signals as well as the high quality image data can be connected with one cable. There is no need to compress the bit rate.

S-video Terminal

This is, called "Super-video", divided into video and color signals for sharper image display.

VHF/UHF

VHF refers to the 2 - 13 channel system; UHF indicates the 14 - 69 channel system.

14-3 L6 Engine Ass'y

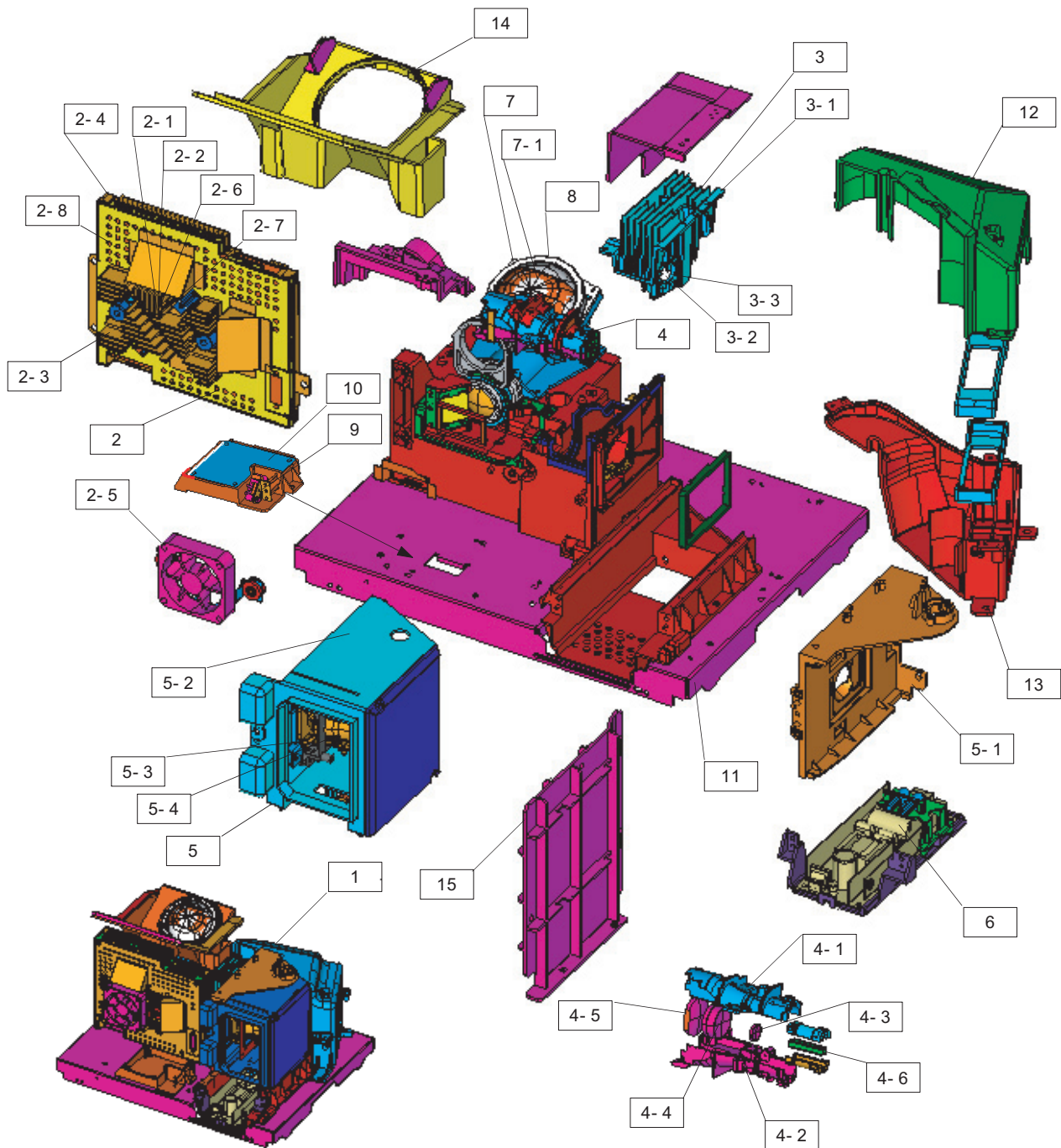

L6 Engine Exploded View List			
No.	Description	Specification	Q'ty
1	ASSY ENGINE P-DLP	42L6,PHILIPS 120W,SVC ENGINE	1
2	ASSY DMD BOARD P	L6 Philips,DMD BOARD,SERVICE	1
2-1	HOLDER-CLAMP DMD	SVP-50L6HR,MG,T2.5,D/C	1
2-2	BRACKET-PANEL	SVP-50L6HR,AL D/C,T3.0	1
2-3	BRACKET-COOLER	SVP-50L6HR,AL,T3.0	1
2-4	SHIELD CASE-DMD(F)	SVP-50L6HR,SECC,T1.0	1
2-5	FAN-DC	AD0612LB-D72GL,P.B.T UL94-Vo,Wire	1
2-6	DLP	1280x720D/HD4,FTP,DMD TYPE A/NON ape	1
2-7	HOLDER-SOCKET DMD	LCP,T3.0,BLACK,203pin	1
2-8	ASSY PCB S-DMD	L620,HURRICANE	1
3	ASSY COLOR WHEEL P	L6,SERVICE	1
3-1	HOLDER-COLOR WHEEL	SVP-50L6HR,MG,T2.5,D/	1
3-2	GLASS-COLOR WHEEL	65mm NDF,FLOAT GLASS,T	1
3-3	GLASS-UV FILTER	HURRICANE,GLASS,NTR,16.5	1
4	ASSY LENS P-ILLUMINATION	L6,SERVICE	1
4-1	HOLDER-L/T(TOP)	SVP-50L6HR,PPS G/F30,T2.	1
4-2	HOLDER-L/T(BOT)	SVP-50L6HR,PPS G/F30	1
4-3	LENS-ILL E1	HURRICANE,NBFD13,NTR,R1=-28.	1
4-4	LENS-ILL E2/E3	HURRICANE,FD60,BACD5,NTR,	1
4-5	LENS-ILL E4	HURRICANE,BACED5,NTR,R1=54.5	1
4-6	MIRROR-LIGHT TUNNEL	HURRICANE,GLASS,3.5x	1
5	ASSY LAMP P	L6 NEW,PHILIPS 120W,E22	1
5-1	HOUSING-LAMP,BOTTOM 23	SVP-50L3HR,AL D/	1
5-2	HOLDER-HOUSING LAMP	SVP-50L6HR,PPS G/F30	1
5-3	HOLDER-LAMP F	DLP L3,AL D/C	1
5-4	LAMP	UHP 100W/120W 1.0,E22,65*70	1
6	LAMP-BALLAST	EUC 120 P/H11,120W,130mm ca	1
7	LENS-P/J ASSY	HURRICANE,GLASS,NTR,FOV=93	1
7-1	LENS-PROJECTION	PMMA,NTR,R1:114.50, R2:27.754,T4,ASP LENS	1
8	GLASS-ACTUATOR	MIRROR,T3.1,27,24,VCN	1
9	ASSY MISC-DETECTOR S/W	HLP5063WX/XAA,L62	1
10	ASSY PCB S-DETECTOR B/D	L620,HURRICANE	1
11	BRACKET-ENGINE BASE	SVP-50L6HR,SECC,T1.6	1
12	COVER-DUCT TOP	SVP-50L6HR,PC G/F20,T3.0	1
13	COVER-DUCT BOT	SVP-50L6HR,PC G/F20,T3.0	1
14	COVER-P/J LENS	SVP-50LLHR,ABS,T2.5	1
15	COVER-LAMP	HURRICANE 720P,PC	1

12. Disassembly & Reassembly

12-1 Overhaul Disassembly & Reassembly

12-1-1 Separation of the back cover and the chassis

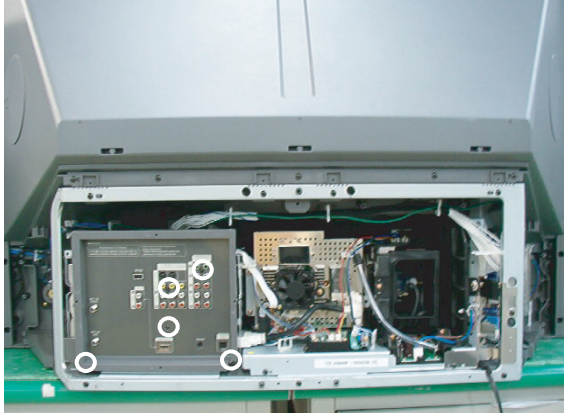
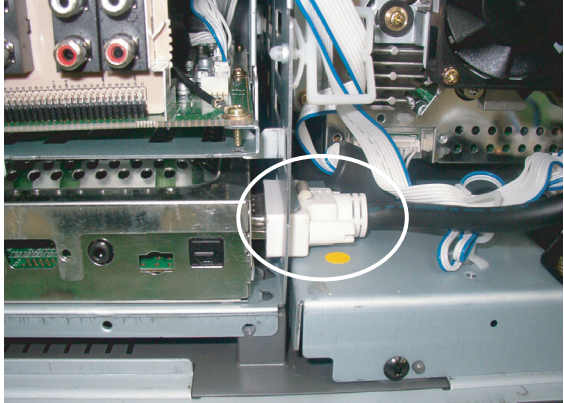
Part Name	Description	Description Photo
Back Cover	① Remove 14 screws to remove the back bottom cover. : TH,B,M4.L15,BLK,SWRCH18A	
Terminal Board	① Loosen and remove the 5 screws on the terminal board and jack. * The 3 Terminal Board Screws. : TH,B,M4.L15,BLK,SWRCH18A * The 2 Jack Screws. : RH,B,M4,L15,ZPC(BLK),SWRCH18	
Holder Chassis	① Separate the DVI cable. ⚠ Notice: The DVI screw is made of soft plastic and may easily break when applying excessive force through a screw driver. Ensure that extreme caution is taken when loosening the screw.	

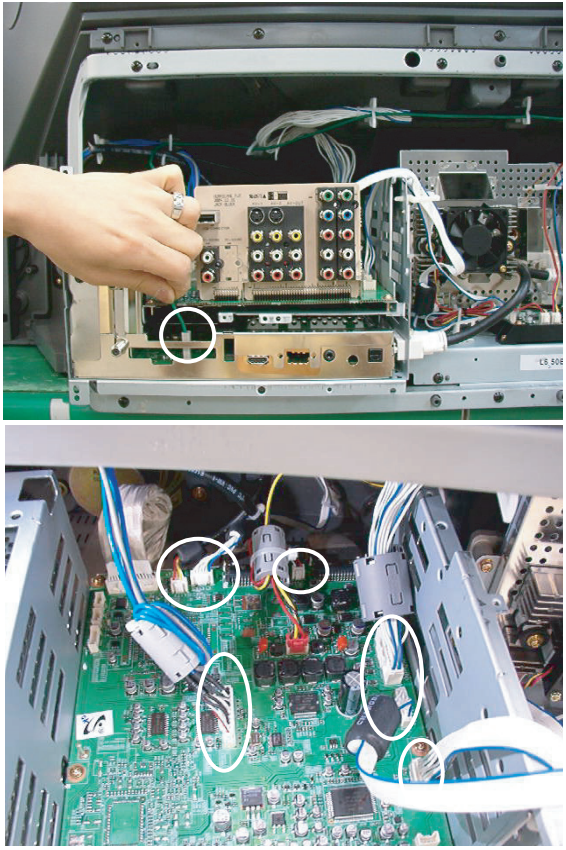
Part Name	Description	Description Photo
Holder Chassis	<ol style="list-style-type: none">① Seperate the Gt-wires.② Seperate the cables.	

12-1-2 Separation of the Analog and Digital Board

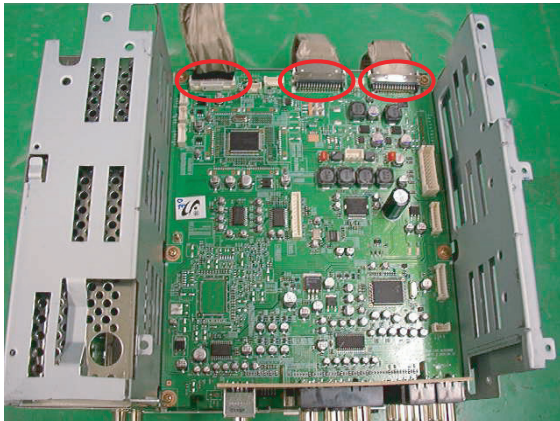
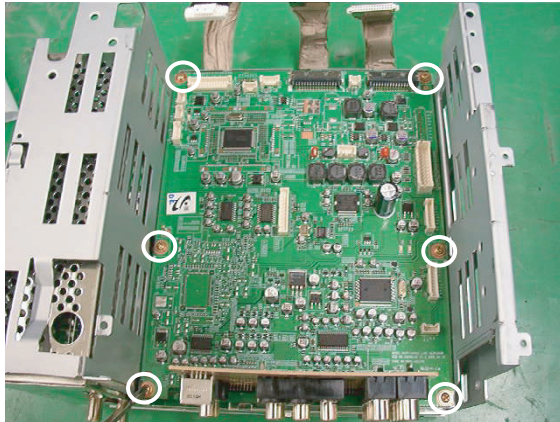
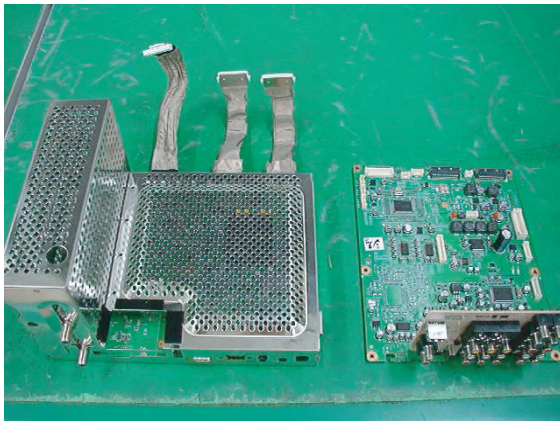
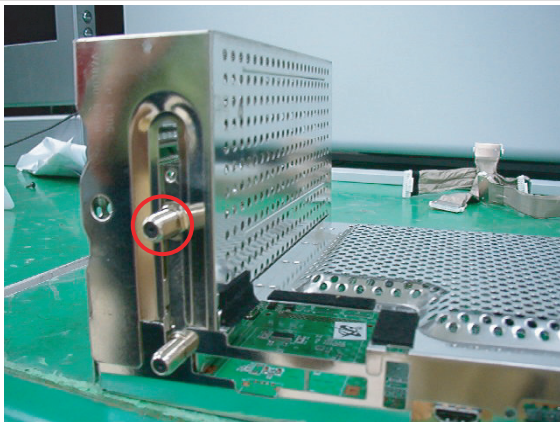
Part Name	Description	Description Photo
Analog Board	<p>① Separate the cables.</p> <p>⚠ Notice: The 30 pin shield cable should be removed by holding the two lock ends of the cable, as failing to do so, could damage the connector.</p>	
	<p>① Remove the 6 screws. : PWH,B,M3,L10,ZPC(YEL),SWRCH18A</p>	
Analog Board/ Digital Board/ Fan	<p>① Analog, Digital Board and Fan.</p>	
Digital Board	<p>① Use the long-nosed pliers to remove the hex nuts. Nut-Hexagon : -,M3/8X32,ZPC(WHT),MBSBD</p>	

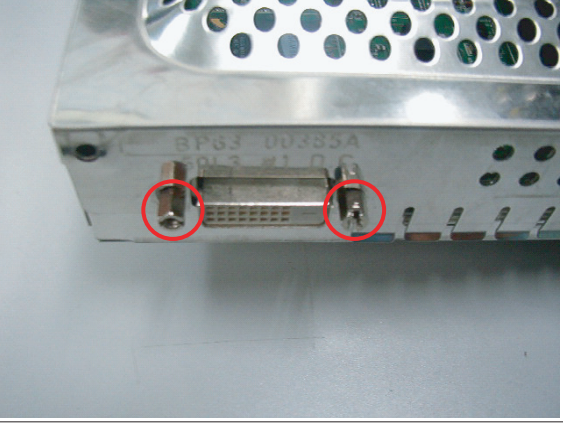
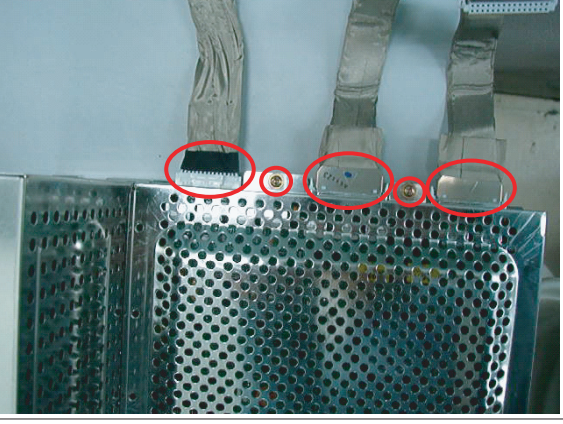
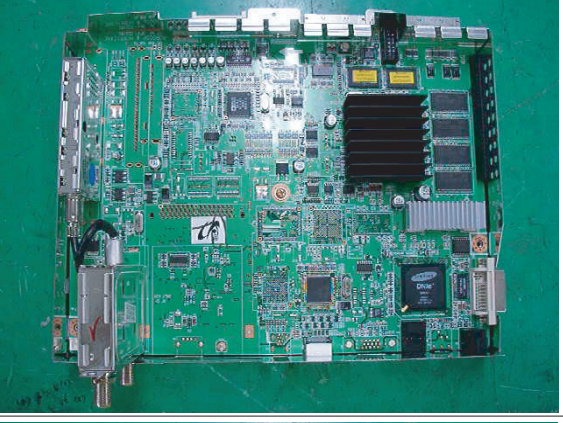
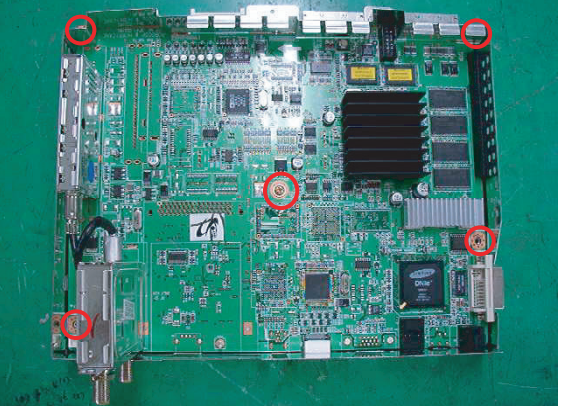
Part Name	Description	Description Photo
Digital Board	<p>① Remove the 2 standoffs. StandOff : M3,L5,Ni PLT,SUM24L,#4-40</p> <p>⚠ Notice: The standoff may easily break through applying excessive force. Ensure that extreme caution is taken.</p>	
	<p>① Remove the 2 screws and 3 cables. : PWH,B,M3,L10,ZPC(YEL),SWRCH18A</p> <p>⚠ Notice: The 30 pin shield cable should be removed by holding the two lock ends of the cable, as failing to do so, could damage the connector.</p>	
	<p>① After Removing the Top Shield Case.</p> <p>⚠ Notice: Use the two lock holes on either side of the shield case when removing it.</p>	
	<p>① Remove the 5 screws before removing the shield case at the bottom. : PWH,B,M3,L10,ZPC(YEL),SWRCH18A</p>	

Part Name	Description	Description Photo
Digital Board	① Digital Board.	

12-1-3 Separation of the Optical Engine

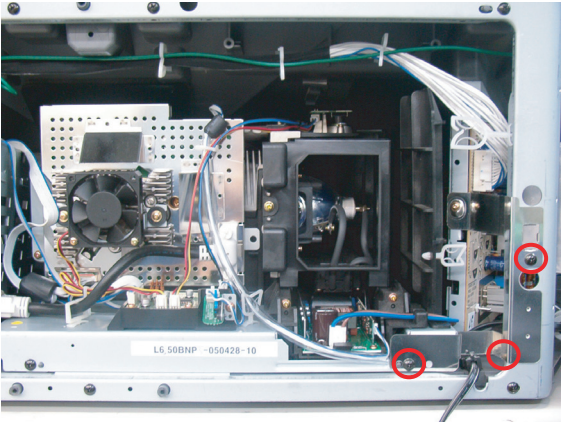
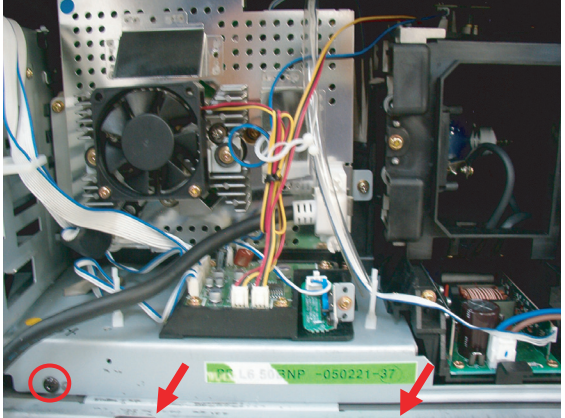
Part Name	Description	Description Photo
Optical Engine	<p>① Remove the 3 screws to remove the bracket. : TH,B,M4.L15,BLK,SWRCH18A</p>	
	<p>① Remove the screw and Remove the engine by pulling it out of the cabinet. : TH,B,M4.L15,BLK,SWRCH18A</p> <p>⚠ Notice: Be careful when removing the Light Engine as it may get caught up by the upper cable of the case.</p>	

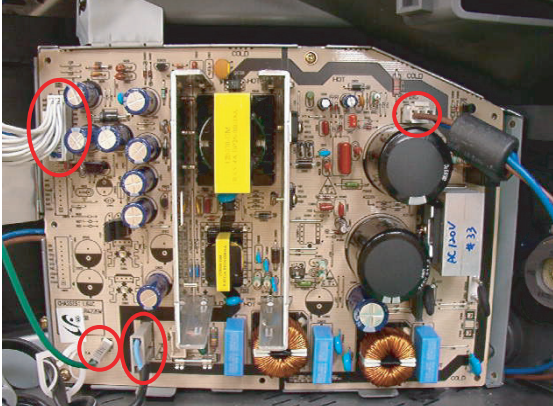
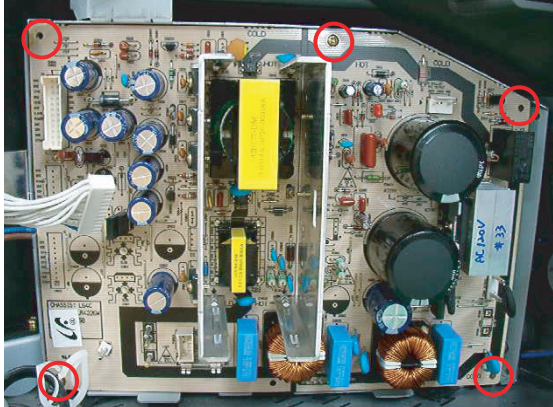

12-1-4 Separation of the Power Board

Part Name	Description	Description Photo
Power Board	<p>① Separate the 4 cables.</p> <p>② After removing 5 screws, Remove the power board carefully.</p> <p>⚠ Notice: Wear gloves when handling the power board as there may be some remaining electrical charge in the capacitors. Specifically, avoid touching any part of the capacitors.</p>	
	<p>① After removing the 3 screws, separate the bottom power bracket. : PWH,B,M3,L10,ZPC(YEL),SWRCH18A</p>	

12-1-5 Lamp Replacement

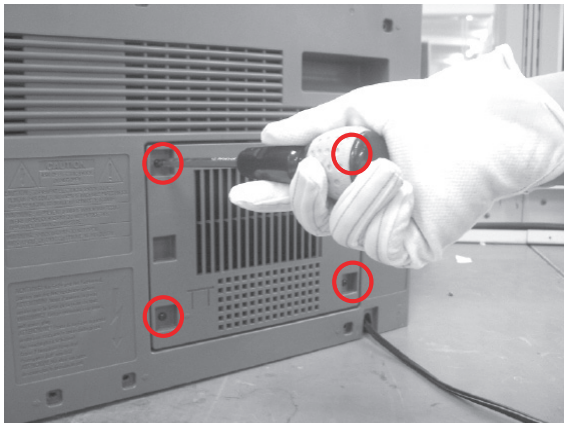

⚠ Notice

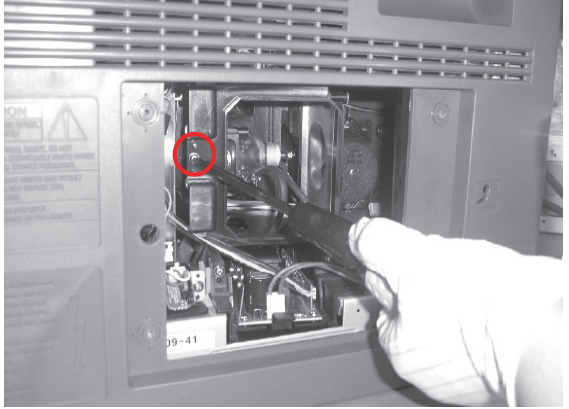
1. Replace with the correct code numbered lamp to avoid damage to the TV.
2. Turn the power off and wait for 30 minutes before replacing the lamp as it will be hot.
3. Do not touch the glass part of the lamp with your bare hands nor insert any foreign object inside the cover as it may cause poor screen quality, electric shock or fire.
4. Do not place the old lamp near flammable objects or within the reach of children.
5. Be sure to connect this TV directly to an AC wall outlet. If the TV's AC plug is connected to a cable box or other source, it will not allow for proper cool down time.

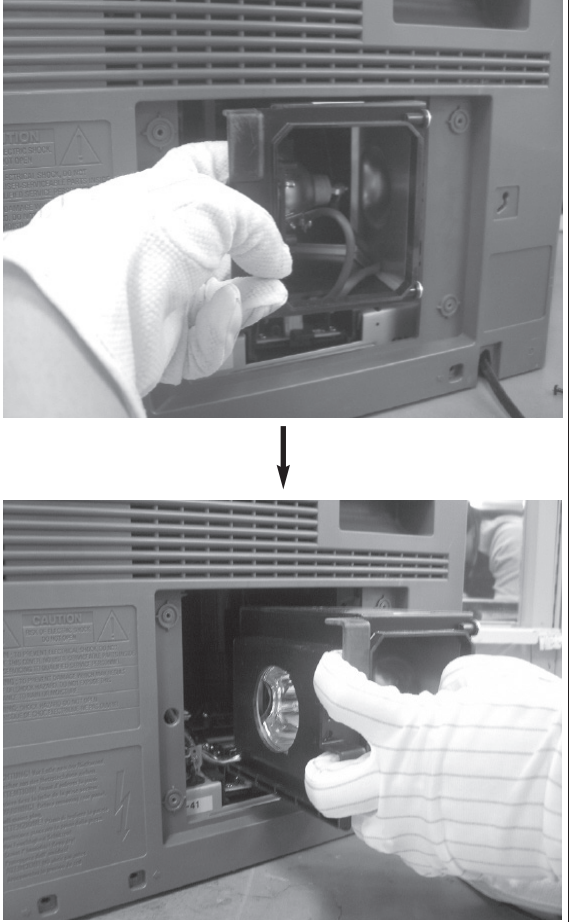

Part Name	Description	Description Photo
Lamp	① Unplug the TV, then use a screwdriver to remove the 4 screws. : WSP,PH,+,M4,L12,ZPC(YEL),SM10C	
	① Remove the Lamp cover.	
	① Remove the screw securing the Lamp by using a screwdriver. : WSP,PH,+,M4,L12,ZPC(YEL),SM10C	

Part Name	Description	Description Photo
Lamp	<p>① Separate the Lamp from the engine by holding the handle and pulling it out.</p> <p>② To reinstall the Lamp, follow these steps in reverse order.</p>	 <p>The 'Description Photo' column contains two sequential images. The top image shows a gloved hand pulling a lamp out of the engine compartment. The bottom image shows a gloved hand pushing the lamp back into the compartment. A downward-pointing arrow is positioned between the two images.</p>

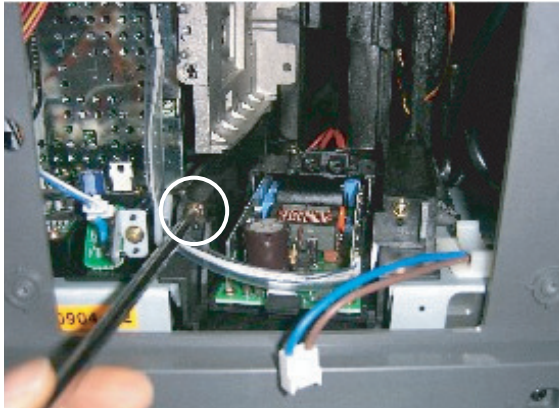
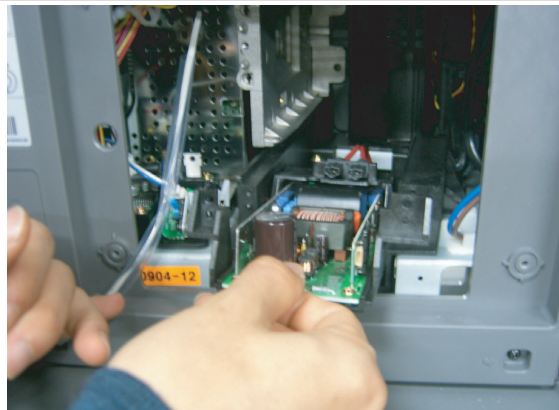
12-1-6 Ballast Replacement

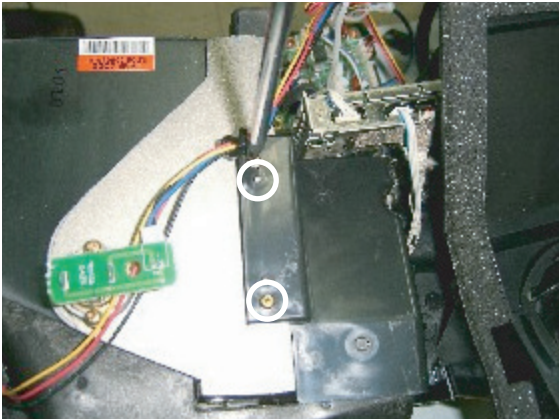
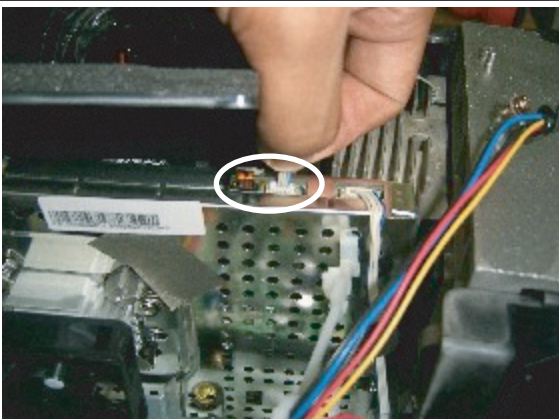

Part Name	Description	Description Photo
Ballast Board	① Remove the lamp, referring to lamp replacement.(12-8page) Remove the ballast power cable.	
	① Remove the Ballast SCI cable.	
	① Remove the two screws at the Holder Ballast. : PWH,+B,M3,L10,ZPC(YEL),SWRCH18A,-	
	① Pull out the Ballast assembly. ② Replace it with a new one and re-assemble it in the reverse order.	

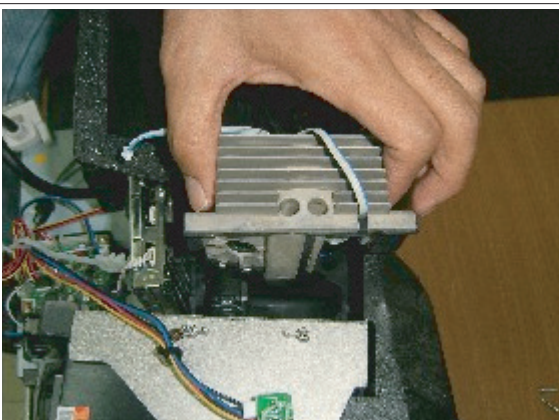
12-1-7 Color Wheel Ass'y Replacement

Part Name	Description	Description Photo
Color Wheel	① Remove 2 screws to remove the color wheel cover. (L620 doesn't have the cover color wheel.) : WSP,PH,+,M3,L8,ZPC(YEL),SW	
	① Remove two cables at the DMD Board.	
	① Remove 2 screws. : PWH,+,B,M3,L10,ZPC(YEL),SWRCH18A,-	
	① Disassemble the color wheel assembly.	

Part Name	Description	Description Photo
<p>Color Wheel</p>	<p>① Replace it with a new color wheel and rubber assembly.</p> <p>⚠ Notice : Never touch the color wheel. Touch only the cover assembly.</p>	

12-1-8 Actuator(Smooth Picture) Replacement

Part Name	Description	Description Photo
Actuator	① Remove the cable at the Actuator.	
	① Push the steel spring wire to bottom of the Actuator Assy.	
	① Replace it with a new actuator.	

MEMO